

# OPERATOR'S MANUAL



## Model C722 Soft Serve Freezer

**Original Operating Instructions**

**080568-M**

2/22/12 (Original Publication)  
Updated 7/17/15

**Complete this page for quick reference when service is required:**

Taylor Distributor: \_\_\_\_\_

Address: \_\_\_\_\_

Phone: \_\_\_\_\_

Service: \_\_\_\_\_

Parts: \_\_\_\_\_

Date of Installation: \_\_\_\_\_

**Information found on the data label:**

Model Number: \_\_\_\_\_

Serial Number: \_\_\_\_\_

Electrical Specs: Voltage \_\_\_\_\_ Cycle \_\_\_\_\_

Phase \_\_\_\_\_

Maximum Fuse Size: \_\_\_\_\_ A

Minimum Wire Ampacity: \_\_\_\_\_ A

© 2012 Carrier Commercial Refrigeration, Inc.  
080568-M

Any unauthorized reproduction, disclosure, or distribution of copies by any person of any portion of this work may be a violation of Copyright Law of the United States of America and other countries, could result in the awarding of Statutory Damages of up to \$250,000 (17 USC 504) for infringement, and may result in further civil and criminal penalties. All rights reserved.



Taylor Company  
a division of Carrier Commercial Refrigeration, Inc.  
750 N. Blackhawk Blvd.  
Rockton, IL 61072

# Table of Contents

---

|                  |   |           |
|------------------|---|-----------|
| <b>Section 1</b> | <b>To the Installer</b> .....                     | <b>1</b>  |
|                  | Installer Safety .....                            | 1         |
|                  | Site Preparation .....                            | 1         |
|                  | Air Cooled Units .....                            | 1         |
|                  | Water Connections (Water Cooled Units Only) ..... | 2         |
|                  | Electrical Connections .....                      | 2         |
|                  | Beater Rotation .....                             | 3         |
|                  | Optional Carts .....                              | 3         |
|                  | Refrigerant .....                                 | 3         |
| <b>Section 2</b> | <b>To the Operator</b> .....                      | <b>4</b>  |
| <b>Section 3</b> | <b>Safety</b> .....                               | <b>5</b>  |
| <b>Section 4</b> | <b>Operator Parts Identification</b> .....        | <b>8</b>  |
|                  | Model C722 .....                                  | 8         |
|                  | Door and Beater Assembly .....                    | 10        |
|                  | X69928-14S Pump A. - Mix Simplified S.S. ....     | 11        |
|                  | Accessories .....                                 | 12        |
|                  | Brushes .....                                     | 13        |
|                  | Optional Carts .....                              | 14        |
| <b>Section 5</b> | <b>Important: To the Operator</b> .....           | <b>15</b> |
|                  | Symbol Definitions .....                          | 16        |
|                  | Operating Screen Descriptions .....               | 18        |
|                  | Manager's Menu .....                              | 19        |
| <b>Section 6</b> | <b>Operating Procedures</b> .....                 | <b>25</b> |
|                  | Assembly .....                                    | 25        |
|                  | Mix Pump Assembly .....                           | 30        |
|                  | Sanitizing .....                                  | 32        |
|                  | Priming .....                                     | 34        |
|                  | Manual Brush Cleaning .....                       | 35        |
|                  | Draining Product From The Freezing Cylinder ..... | 35        |
|                  | Rinsing .....                                     | 35        |

|   |           |
|---|-----------|
| Hopper Cleaning .....                                 | 36        |
| Disassembly .....                                     | 36        |
| Brush Cleaning .....                                  | 37        |
| <b>Section 7 Important: Operator Checklist .....</b>  | <b>38</b> |
| During Cleaning and Sanitizing .....                  | 38        |
| Troubleshooting Bacterial Count .....                 | 38        |
| Regular Maintenance Checks .....                      | 38        |
| Winter Storage .....                                  | 39        |
| <b>Section 8 Troubleshooting Guide .....</b>          | <b>40</b> |
| <b>Section 9 Parts Replacement Schedule .....</b>     | <b>44</b> |
| <b>Section 10 Limited Warranty on Equipment .....</b> | <b>45</b> |
| <b>Section 11 Limited Warranty on Parts .....</b>     | <b>47</b> |

**Note: Continuing research results in steady improvements; therefore, information in this manual is subject to change without notice.**

**Note: Only instructions originating from the factory or its authorized translation representative(s) are considered to be the original set of instructions.**

© 2012 Carrier Commercial Refrigeration, Inc. (Original Publication)  
Updated July, 2015  
080568-M

Any unauthorized reproduction, disclosure, or distribution of copies by any person of any portion of this work may be a violation of Copyright Law of the United States of America and other countries, could result in the awarding of Statutory Damages of up to \$250,000 (17 USC 504) for infringement, and may result in further civil and criminal penalties.

All rights reserved.



Taylor Company  
a division of Carrier Commercial Refrigeration, Inc.  
750 N. Blackhawk Blvd.  
Rockton, IL 61072

# Section 1

# To the Installer

The following information has been included in the manual as safety and regulatory guidelines. For complete installation instructions, please see the Installation Checklist.



This unit has many sharp edges that can cause severe injuries.

## Installer Safety



In all areas of the world, equipment should be installed in accordance with existing local codes. Please contact your local authorities if you have any questions.

Care should be taken to ensure that all basic safety practices are followed during the installation and servicing activities related to the installation and service of Taylor equipment.

- Only authorized Taylor service personnel should perform installation and repairs on the equipment.
- Authorized service personnel should consult OSHA Standard 29CFR1910.147 or the applicable code of the local area for the industry standards on lockout/tagout procedures before beginning any installation or repairs.
- Authorized service personnel must ensure that the proper PPE is available and worn when required during installation and service.
- Authorized service personnel must remove all metal jewelry, rings, and watches before working on electrical equipment.



The main power supply(s) to the freezer must be disconnected prior to performing any repairs. Failure to follow this instruction may result in personal injury or death from electrical shock or hazardous moving parts as well as poor performance or damage to the equipment.

**Note: All repairs must be performed by an authorized Taylor Service Technician.**

## Site Preparation

Review the area where the unit will be installed before uncrating the unit. Make sure all possible hazards to the user or equipment have been addressed.

## Air Cooled Units

The Model C722 air cooled unit requires a minimum of 6" (152 mm) on the left and right sides and 0" on the back. The C722 equipped with top air discharge requires 6" (152 mm) on the left side, 0" on the right side, and 0" on the back.

This will allow for adequate air flow across the condenser. Failure to allow adequate clearance can reduce the refrigeration capacity of the freezer and possibly cause permanent damage to the compressor.

**For Indoor Use Only:** This unit is designed to operate indoors, under normal ambient temperatures of 70°-75°F (21°-24°C). The freezer has successfully performed in high ambient temperatures of 104°(40°C) at reduced capacities.



This unit must **NOT** be installed in an area where a water jet or hose can be used. **NEVER** use a water jet or hose to rinse or clean the unit. Failure to follow this instruction may result in electrocution.



This unit must be installed on a level surface to avoid the hazard of tipping. Extreme care should be taken in moving this equipment for any reason. Two or more people are required to safely move this unit. Failure to comply may result in personal injury or equipment damage.

Uncrate the unit and inspect it for damage. Report any damage to your Taylor Distributor.

This piece of equipment is made in the USA and has USA sizes of hardware. All metric conversions are approximate and vary in size.

## Water Connections

### (Water Cooled Units Only)

An adequate cold water supply must be provided with a hand shut-off valve. On the underside of the base pan or on the right side, two 3/8" I.P.S. water connections for inlet and outlet are provided for easy hook-up. 1/2" inside diameter water lines should be connected to the machine. (Flexible lines are recommended, if local codes permit.) Depending on local water conditions, it may be advisable to install a water strainer to prevent foreign substances from clogging the automatic water valve. There will be only one water "in" and one water "out" connection. **DO NOT** install a hand shut-off valve on the water "out" line! Water should always flow in this order: First, through the automatic water valve; second, through the condenser; and third, through the outlet fitting to an **open trap drain**.



**A back flow prevention device is required on the incoming water connection side.** Please refer to the applicable National, State, and local codes for determining the proper configuration.

## Electrical Connections

In the United States, this equipment is intended to be installed in accordance with the National Electrical Code (NEC), ANSI/NFPA 70-1987. The purpose of the NEC is the practical safeguarding of persons and property from hazards arising from the use of electricity. This code contains provisions considered necessary for safety. In all other areas of the world, equipment should be installed in

accordance with the existing local codes. Please contact your local authorities.



### **FOLLOW YOUR LOCAL ELECTRICAL CODES!**

Each unit requires one power supply for each data label on the unit. Check the data label(s) on the freezer for branch circuit overcurrent protection or fuse, circuit ampacity, and other electrical specifications. Refer to the wiring diagram provided inside of the electrical box for proper power connections.



**CAUTION: THIS EQUIPMENT MUST BE PROPERLY GROUNDED! FAILURE TO DO SO CAN RESULT IN SEVERE PERSONAL INJURY FROM ELECTRICAL SHOCK!**



**DO NOT** operate this freezer with larger fuses than specified on the unit data label. Failure to follow this instruction may result in electrocution or damage to the machine.



This unit is provided with an equipotential grounding lug that is to be properly attached to the rear of the frame by the authorized installer. The installation location is marked by the equipotential bonding symbol (5021 of IEC 60417-1) on both the removable panel and the equipment's frame.



Stationary appliances which are not equipped with a power cord and a plug or another device to disconnect the appliance from the power source, must have an all-pole disconnecting device with a contact gap of at least 3 mm installed in the external installation.



Appliances that are permanently connected to fixed wiring and for which leakage currents may exceed 10 mA, particularly when disconnected or not used for long periods, or during initial installation, shall have protective devices such as a GFI, to protect against the leakage of current, installed by the authorized personnel to the local codes.



Supply cords used with this unit shall be oil-resistant, sheathed flexible cable not lighter than ordinary polychloroprene or other equivalent synthetic elastomer-sheathed cord (Code designation 60245 IEC 57) installed with the proper cord anchorage to relieve conductors from strain, including twisting, at the terminals and protect the insulation of the conductors from abrasion.

If the supply cord is damaged, it must be replaced by the manufacturer, its service agent, or similarly qualified person, in order to avoid a hazard.

## Beater Rotation



Beater rotation must be clockwise as viewed looking into the freezing cylinder.

**Note:** The following procedures should be performed by a trained service technician.

To correct the rotation on a three-phase unit, interchange any two incoming power supply lines at freezer main terminal block only.

To correct rotation on a single-phase unit, change the leads inside the beater motor. (Follow the diagram printed on the motor.)

Electrical connections are made directly to the terminal block provided in the splice box.

## Optional Carts

There are two optional carts available.

1. **C20600-AFB: ADA compliant height cart, not equipped with a door.**
2. **C20600-000: Standard height cart with reversible front door panel and rear panel.**  
**Note:** If the door is required on the rear of the cart instead of the front, the front door panel and the rear panel can be reversed. To reverse these panels, remove the five screws on each panel. Reverse and reinstall the panels, making sure **all** screws are reinstalled.



**IMPORTANT! For safety purposes, the freezer must be bolted to the cart using all 4 bolts.** Failure to comply could result in personnel injury and equipment damage.

## Refrigerant



In consideration of our environment, Taylor uses only earth friendly HFC refrigerants. The HFC refrigerant used in this unit is R404A. This refrigerant is generally considered non-toxic and non-flammable, with an Ozone Depleting Potential (ODP) of zero (0).

However, any gas under pressure is potentially hazardous and must be handled with caution. NEVER fill any refrigerant cylinder completely with liquid. Filling the cylinder to approximately 80% will allow for normal expansion.



Use only R404A refrigerant that conforms to the AHRI standard 700 specification. The use of any other refrigerant may expose users and operators to unexpected safety hazards.



Refrigerant liquid sprayed onto the skin may cause serious damage to tissue. Keep eyes and skin protected. If refrigerant burns should occur, flush immediately with cold water. If burns are severe, apply ice packs and contact a physician immediately.



Taylor reminds technicians to be cautious of government laws regarding refrigerant recovery, recycling, and reclaiming systems. If you have any questions regarding these laws, please contact the factory Service Department.



**WARNING:** R404A refrigerant used in conjunction with polyolester oils is extremely moisture absorbent. When opening a refrigeration system, the maximum time the system is open must not exceed 15 minutes. Cap all open tubing to prevent humid air or water from being absorbed by the oil.

# Section 2

# To the Operator

Your freezer has been carefully engineered and manufactured to give you dependable operation.

This unit, when properly operated and cared for, will produce a consistent quality product. Like all mechanical products, it will require cleaning and maintenance. A minimum amount of care and attention is necessary if the operating procedures outlined in this manual are followed closely.

This Operator's Manual should be read before operating or performing any maintenance on your equipment.

Your Taylor freezer will NOT eventually compensate for, and correct, any errors during the set-up or filling operations. Thus, the initial assembly and priming procedures are of extreme importance. It is strongly recommended that personnel responsible for the equipment's operation, both assembly and disassembly, go through these procedures together in order to be properly trained and to make sure that no confusion exists.

In the event you should require technical assistance, please contact your local authorized Taylor Distributor.

**Note:** Your Taylor warranty is valid only if the parts are authorized Taylor parts, purchased from the local authorized Taylor Distributor, and only if all required service work is provided by an authorized Taylor service technician. Taylor reserves the right to deny warranty claims on units or parts if non-Taylor approved parts or incorrect refrigerant were installed in the unit, system modifications were performed beyond factory recommendations, or it is determined that the failure was caused by abuse, misuse, neglect, or failure to follow all operating instructions. For full details of your Taylor Warranty, please see the Limited Warranty section in this manual.

**Note: Constant research results in steady improvements; therefore, information in this manual is subject to change without notice.**



If the crossed out wheeled bin symbol is affixed to this product, it signifies that this product is compliant with the EU Directive as well as other

similar legislation in effect after August 13, 2005. Therefore, it must be collected separately after its use is completed, and cannot be disposed as unsorted municipal waste. The user is responsible for returning the product to the appropriate collection facility, as specified by the local code.

For additional information regarding applicable local laws, please contact the municipal facility and/or local distributor.

## Compressor Warranty Disclaimer

The refrigeration compressor(s) on this unit are warranted for the term stated in the Limited Warranty section in this manual. However, due to the Montreal Protocol and the U.S. Clean Air Act Amendments of 1990, many new refrigerants are being tested and developed, thus seeking their way into the service industry. Some of these new refrigerants are being advertised as drop-in replacements for numerous applications. It should be noted that in the event of ordinary service to this unit's refrigeration system, **only the refrigerant specified on the affixed data label should be used.** The unauthorized use of alternate refrigerants will void your Taylor compressor warranty. It is the unit owner's responsibility to make this fact known to any technician he employs.

It should also be noted that Taylor does not warrant the refrigerant used in its equipment. For example, if the refrigerant is lost during the course of ordinary service to this machine, Taylor has no obligation to either supply or provide its replacement either at billable or unbillable terms. Taylor does have the obligation to recommend a suitable replacement if the original refrigerant is banned, obsoleted, or no longer available during the five year warranty of the compressor.

Taylor will continue to monitor the industry and test new alternates as they are being developed. Should a new alternate prove, through our testing, that it would be accepted as a drop-in replacement, then the above disclaimer would become null and void. To find out the current status of an alternate refrigerant as it relates to your compressor warranty, call the local Taylor Distributor or the Taylor Factory. Be prepared to provide the Model/Serial Number of the unit in question.



We, at Taylor Company, are concerned about the safety of the operator when he or she comes in contact with the freezer and its parts. Taylor has gone to extreme efforts to design and manufacture built-in safety features to protect both you and the service technician. As an example, warning labels have been attached to the freezer to further point out safety precautions to the operator.

### To Operate Safely:



**IMPORTANT - Failure to adhere to the following safety precautions may result in severe personal injury or death. Failure to comply with these warnings may damage the machine and its components. Component damage will result in part replacement expense and service repair expense.**



**DO NOT** operate the freezer without reading this Operator Manual. Failure to follow this instruction may result in equipment damage, poor freezer performance, health hazards, or personal injury.



This appliance is to be used only by trained personnel. It is not intended for use by children or people with reduced physical, sensory, or mental capabilities, or lack of experience and knowledge, unless given supervision or instruction concerning the use of the appliance by a person responsible for their safety. Children should be supervised to ensure that they do not play with the appliance.



This unit is provided with an equipotential grounding lug that is to be properly attached to the rear of the frame by the authorized installer. The installation location is marked by the equipotential bonding symbol (5021 of IEC 60417-1) on both the removable panel and the equipment's frame.



**DO NOT** use a water jet to clean or rinse the freezer. Failure to follow these instructions may result in serious electrical shock.



- **DO NOT** operate the freezer unless it is properly grounded.
- **DO NOT** operate the freezer with larger fuses than specified on the data label.
- All repairs must be performed by an authorized Taylor service technician.
- The main power supplies to the machine must be disconnected prior to performing any repairs.
- Cord Connected Units: Only Taylor authorized service technicians or licensed electricians may install a plug or replacement cord on these units.
- Stationary appliances which are not equipped with a power cord and a plug or another device to disconnect the appliance from the power source, must have an all-pole disconnecting device with a contact gap of at least 3 mm installed in the external installation.
- Appliances that are permanently connected to fixed wiring and for which leakage currents may exceed 10 mA, particularly when disconnected or not used for long periods, or during initial installation, shall have protective devices such as a GFI, to protect against the leakage of current, installed by the authorized personnel to the local codes.
- Supply cords used with this unit shall be oil-resistant, sheathed flexible cable, not lighter than ordinary polychloroprene or other equivalent synthetic elastomer-sheathed cord (Code designation 60245 IEC 57) installed with the proper cord anchorage to relieve conductors from strain, including twisting, at the terminals and protect the insulation of the conductors from abrasion.

If the supply cord is damaged, it must be replaced by the manufacturer, its service agent, or similarly qualified person, in order to avoid a hazard.

Failure to follow these instructions may result in electrocution. Contact your local authorized Taylor Distributor for service.



- **DO NOT** allow untrained personnel to operate this machine.
- **DO NOT** operate the freezer unless all service panels and access doors are restrained with screws.
- **DO NOT** remove any internal operating parts (examples: freezer door, beater, scraper blades, etc.) unless all control switches are in the OFF position.

Failure to follow these instructions may result in severe personal injury to fingers or hands from hazardous moving parts.



This unit has many sharp edges that can cause severe injuries.

- **DO NOT** put objects or fingers in the door spout. This may contaminate the product and cause severe personal injury from blade contact.
- **USE EXTREME CAUTION** when removing the beater assembly. The scraper blades are very sharp.
- **CAUTION-SHARP EDGES:** Two people are required to handle the cup/cone dispenser. Protective gloves must be worn and the mounting holes must NOT be used to lift or hold the dispenser. Failure to follow this instruction can result in personal injury to fingers or equipment damage.



Access to the service area of the unit is restricted to persons having knowledge and practical experience with the appliance, in particular as far as safety and hygiene are concerned.



This machine must be placed on a level surface. Extreme care should be taken in moving it for any reason. Two or more persons are required to safely move this machine. Failure to comply may result in personal injury or equipment damage.



Cleaning and sanitizing schedules are governed by your state or local regulatory agencies and must be followed accordingly. Please refer to the cleaning section of this manual for the proper procedure to clean this unit.



This machine is designed to maintain product temperature under 41°F (5°C). Any product being added to this machine must be below 41°F (5°C). Failure to follow this instruction may result in health hazards and poor freezer performance.

**DO NOT** obstruct air intake and discharge openings:

The Model C722 air cooled unit requires a minimum of 6" (152 mm) on the left and right sides and 0" on the back. The C722 equipped with top air discharge requires 6" (152 mm) on the left side, 0" on the right side, and 0" on the back. This will allow for adequate air flow across the condenser. Failure to allow adequate clearance can reduce the refrigeration capacity of the freezer and possibly cause permanent damage to the compressor.

**For Indoor Use Only:** This unit is designed to operate indoors, under normal ambient temperatures of 70 - 75°F (21 - 24°C). The freezer has successfully performed in high ambient temperatures of 104°F (40°C) at reduced capacities.

**DO NOT** run the machine without product. Failure to follow this instruction can result in damage to the machine.

**NOISE LEVEL:** Airborne noise emission does not exceed 78 dB(A) when measured at a distance of 1.0 meter from the surface of the machine and at a height of 1.6 meters from the floor.



# Section 4

# Operator Parts Identification

Model C722

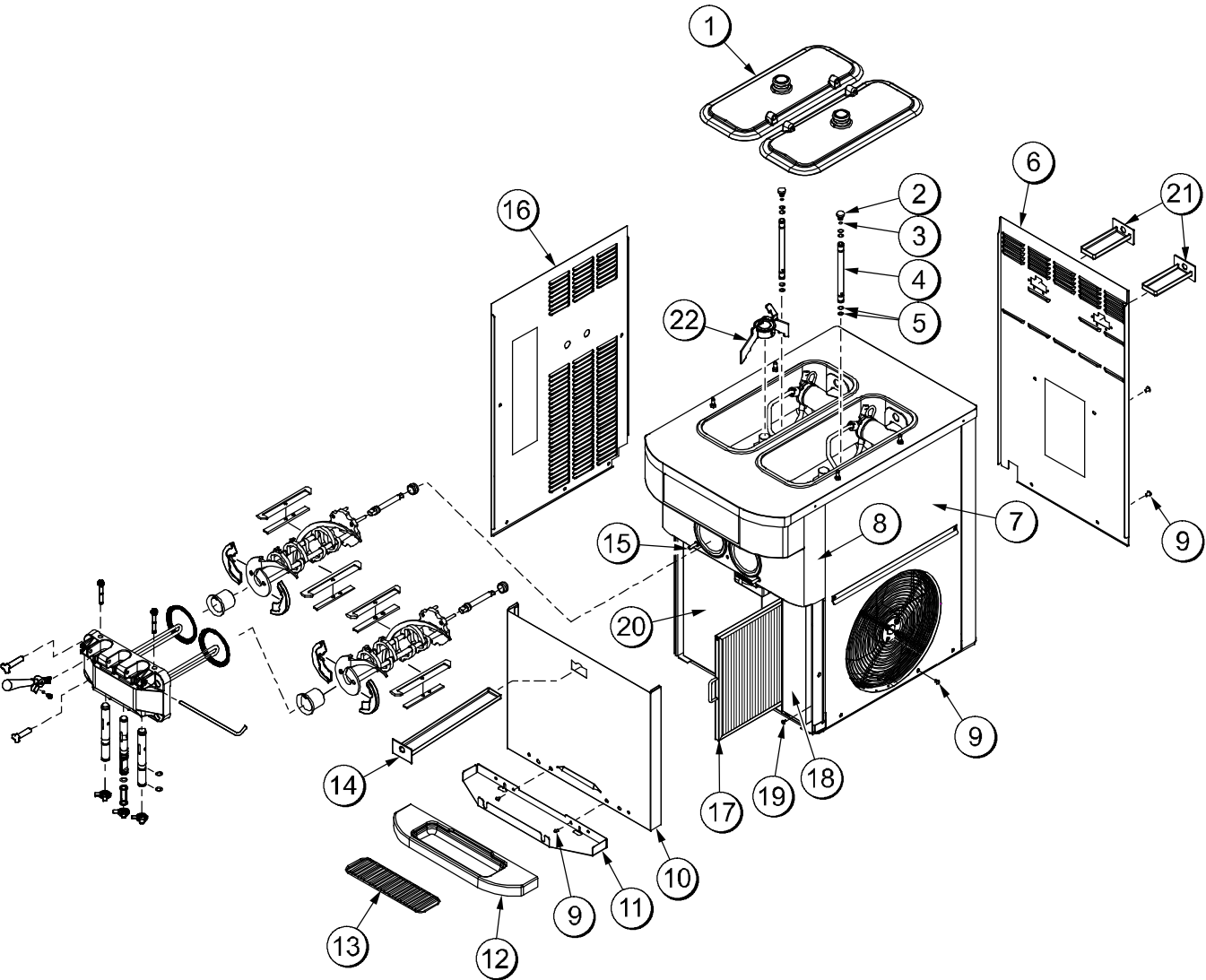

Figure 1

## Model C722 Exploded View Parts Identification

| ITEM | DESCRIPTION                 | PART NO.   |
|------|-----------------------------|------------|
| 1    | KIT A.-HOPPER CVR 14 QT BLA | X69146     |
| 2    | ORIFICE                     | 022465-100 |
| 3    | O-RING-11/16 OD X .103W RED | 016132     |
| 4    | TUBE A.-FEED-SS-5/32 HOLE   | X29429-2   |
| 5    | O-RING-.643 OD X .077W      | 018572     |
| 6    | PANEL-REAR                  | 080162     |
| 7    | PANEL A.-SIDE RIGHT         | X68854     |
| 8    | PANEL A.-FRONT              | X81843     |
| 9    | SCREW-1/4-20X3/8 SLOTTED    | 011694     |
| 10   | PANEL A.-FRONT-LOWER        | X81841     |
| 11   | SHELF-DRIP TRAY             | 080782     |
| 12   | TRAY-DRIP                   | 080781     |

| ITEM | DESCRIPTION               | PART NO.  |
|------|---------------------------|-----------|
| 13   | SHIELD-SPLASH-WIRE        | 046177-SP |
| 14   | PAN A.-DRIP 15 1/8 LONG   | X51601    |
| 15   | STUD-NOSE CONE            | 055987    |
| 16   | PANEL-SIDE LEFT           | 068851    |
| 17   | FILTER A.                 | X81440    |
| 17A  | FILTER-AIR-18.28X15.5X.70 | 052779-15 |
| 18   | COVER-ACCESS-FRONT-R.     | 056933    |
| 19   | SCREW-10X3/8 SLOTTED HEX  | 015582    |
| 20   | COVER-ACCESS-LEFT         | 081834    |
| 21   | PAN-DRIP-REAR             | 080226    |
| *22  | BLADE A.-AGITATOR         | X56591-SP |

\*FACTORY-EQUIPPED AGITATOR UNITS, ONLY

# Door and Beater Assembly

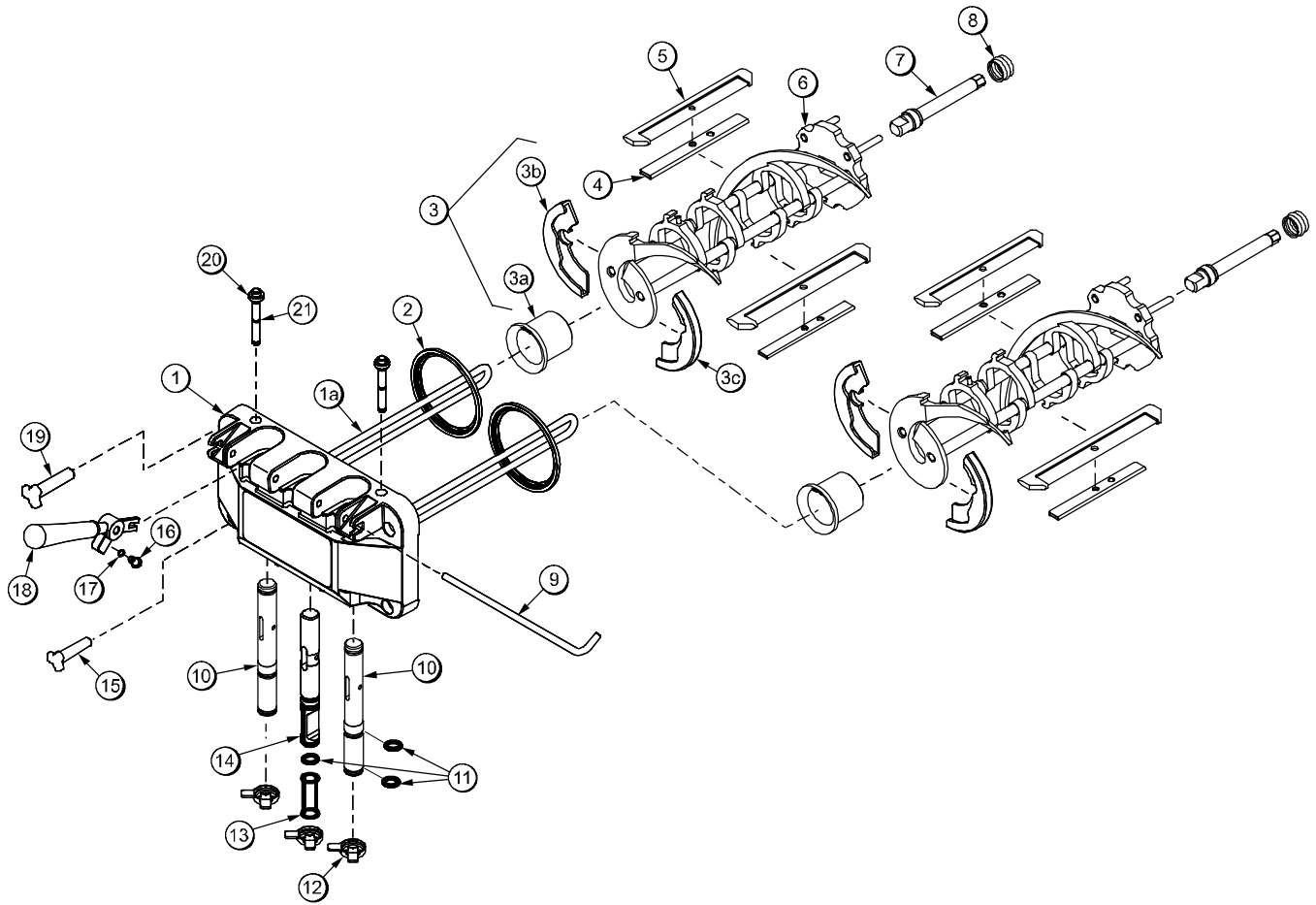

Figure 2

| ITEM | DESCRIPTION                       | PART NO.   |
|------|-----------------------------------|------------|
| 1    | DOOR A.-SH BAF-W/PRG              | X68889-SER |
| 1a   | BAFFLE A.-SHORT 4"                | X50883     |
| 2    | GASKET-DOOR HT 4"-DOUBLE          | 048926     |
| 3    | KIT A.-BEATER-FRONT SHOES-BEARING | X50350     |
| 3a   | BEARING-FRONT SHOE                | *SEE NOTE  |
| 3b   | SHOE-FRONT HELIX-FRONT            | *SEE NOTE  |
| 3c   | SHOE-FRONT HELIX-REAR             | *SEE NOTE  |
| 4    | CLIP-SCRAPER BLADE 5.50"          | 080293     |
| 5    | BLADE-SCRAPER-PLASTIC             | 080292     |
| 6    | BEATER A.-2.8QT-1 PIN             | X80291     |
| 7    | SHAFT-BEATER                      | 081707     |
| 8    | SEAL-DRIVE SHAFT                  | 032560     |

| ITEM | DESCRIPTION                 | PART NO. |
|------|-----------------------------|----------|
| 9    | PIN-HANDLE-TWIN             | 059894   |
| 10   | VALVE A.-DRAW               | X69615   |
| 11   | O-RING-7/8 OD X .103W       | 083693   |
| 12   | CAP-DESIGN 1.010"ID-6 POINT | 014218   |
| 13   | SEAL-DRAW VALVE-LARGE H     | 034698   |
| 14   | VALVE A.-DRAW-CENTER        | X62218   |
| 15   | NUT-STUD-BLACK 2.563 LONG   | 058764   |
| 16   | SCREW-ADJUSTMENT-5/16-24    | 056332   |
| 17   | O-RING-1/4 OD X .070W       | 015872   |
| 18   | HANDLE A.-DRAW              | X56421-1 |
| 19   | NUT-STUD-BLACK 3.250 LONG   | 058765   |
| 20   | PLUG-PRIME TWIN             | 059936   |
| 21   | O-RING-1/2OD X .070W        | 024278   |

\*NOT AVAILABLE SEPARATELY. ORDER X50350 KIT.

## X69928-14S Pump A. - Mix Simplified S.S.

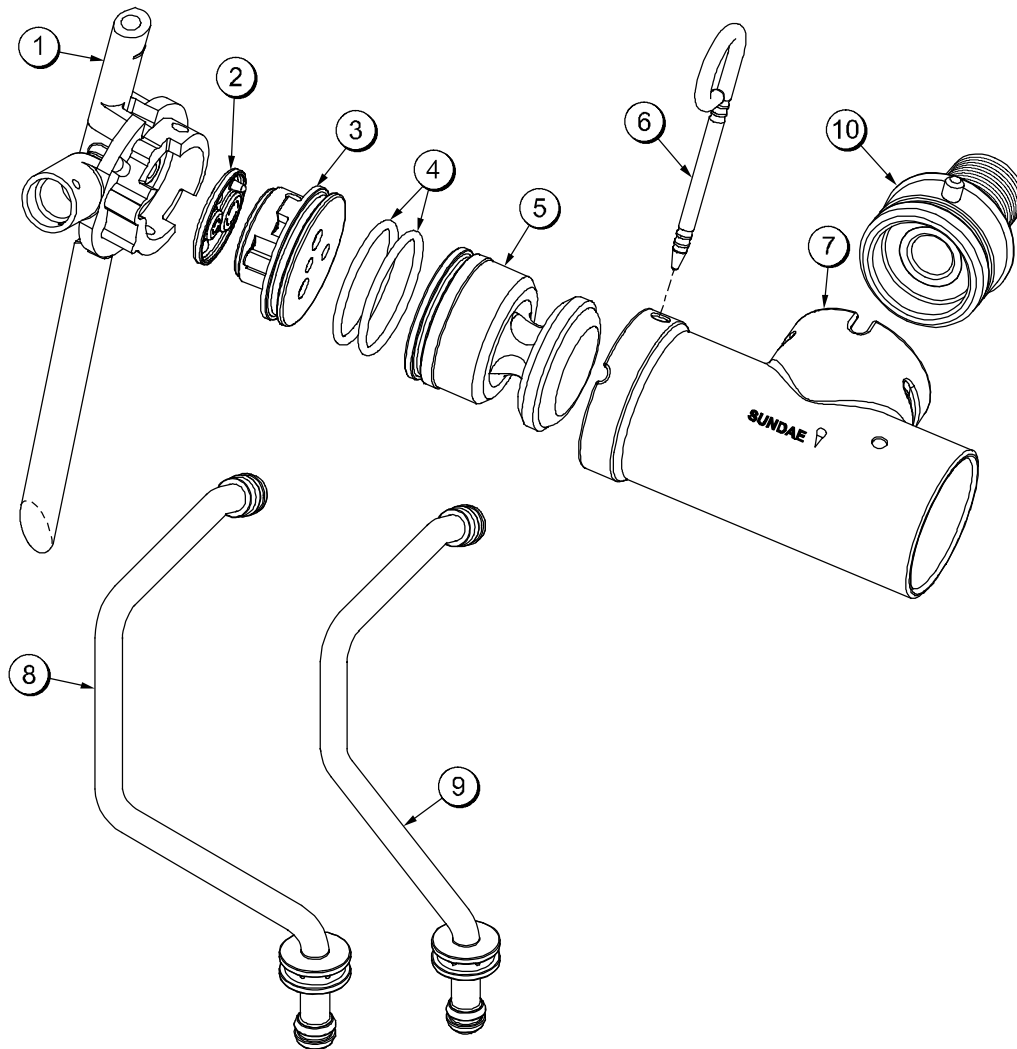

Figure 3

| ITEM  | DESCRIPTION                  | PART NO.   |
|-------|------------------------------|------------|
| 1 - 7 | PUMP A.-MIX SIMPLIFIED S.S.  | X69928-14S |
| 1     | ADAPTOR-MIX INLET-SS-RED     | 069921     |
| 2     | GASKET-SIMPLIFIED PUMP VALVE | 053527     |
| 3     | CAP-VALVE BODY SS            | 056874-14  |
| 4     | O-RING-2-1/8 OD X .139W-#225 | 020051     |
| 5     | PISTON-PUMP-SIMPL.-SHORT     | 069922     |

| ITEM | DESCRIPTION                       | PART NO. |
|------|-----------------------------------|----------|
| 6    | PIN-RETAINING                     | X55450   |
| 7    | CYLINDER-PUMP HOPPER<br>SOFTSERVE | 069920   |
| 8    | TUBE A.-FEED-LEFT *C722*          | X69919   |
| 9    | TUBE A.-FEED-RIGHT *C722*         | X69924   |
| 10   | SLEEVE A.-MIX PUMP *HT*           | X44761   |

# Accessories

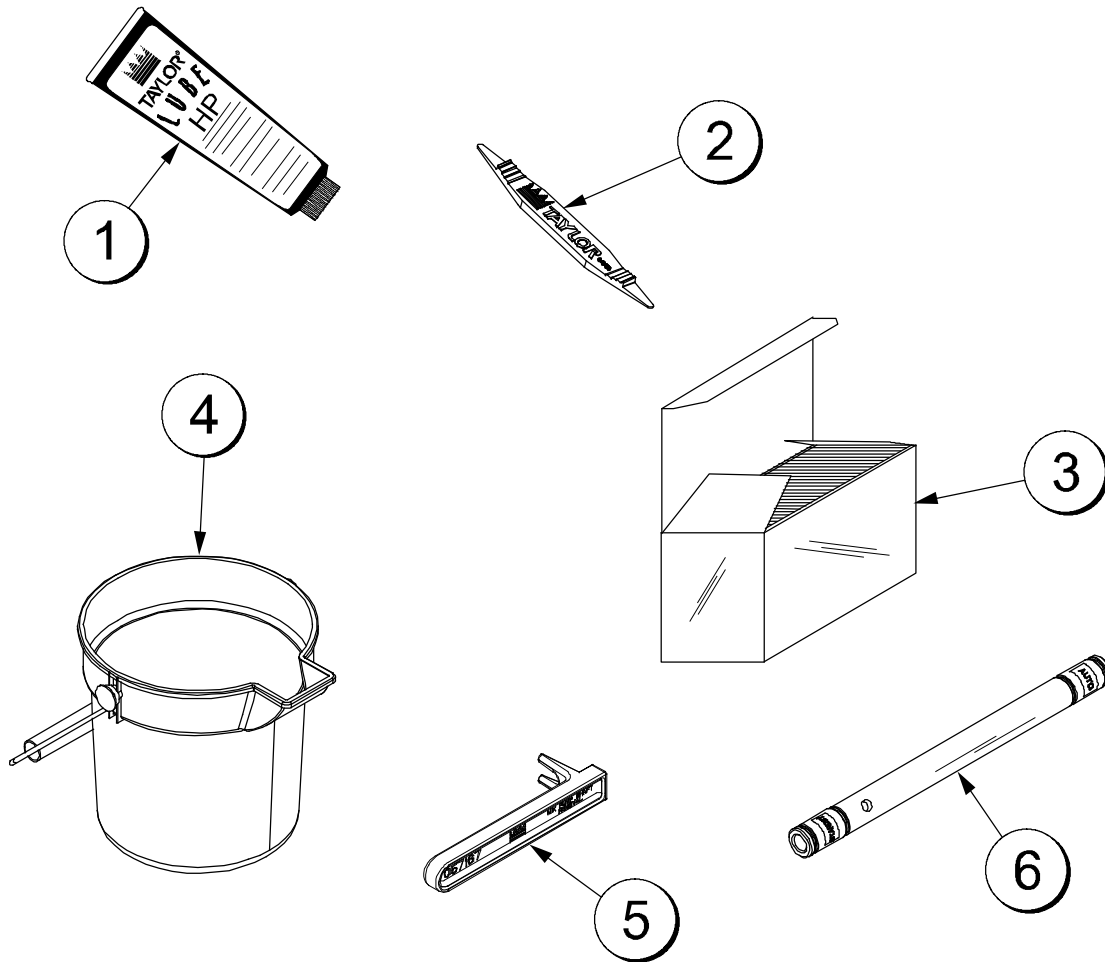

Figure 4

| ITEM | DESCRIPTION           | PART NO.   |
|------|-----------------------|------------|
| 1    | LUBRICANT-TAYLOR      | 047518     |
| 2    | TOOL-O-RING REMOVAL   | 048260-WHT |
| *3   | SANITIZER-STERA SHEEN | SEE NOTE   |
| 4    | PAIL-10 QT            | 013163     |

| ITEM | DESCRIPTION                 | PART NO.  |
|------|-----------------------------|-----------|
| 5    | TOOL-MIX PUMP SHAFT REMOVAL | 057167    |
| 6    | TUBE A.-FEED-SS-5/32 HOLE   | X29429-2  |
| **   | KIT A.-TUNE-UP              | X49463-81 |

\*A sample container of sanitizer is sent with the unit. For reorders, order Stera Sheen part no. 055492 (100 2 oz. packs) or Kay-5 part no. 041082 (200 packs).

\*\*Not Shown.



# Brushes

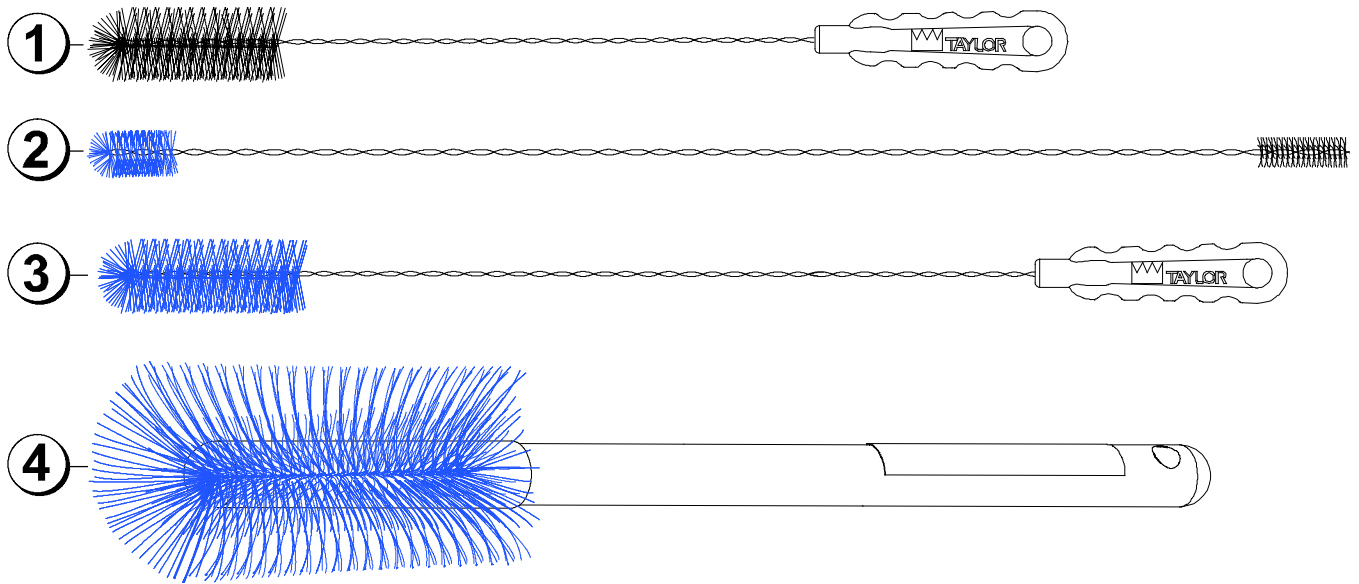

Figure 5

| ITEM | DESCRIPTION               | PART NO. |
|------|---------------------------|----------|
| 1    | BRUSH-REAR BRG. - 1" X 2" | 013071   |
| 2    | BRUSH-DOUBLE END          | 013072   |

| ITEM | DESCRIPTION                 | PART NO. |
|------|-----------------------------|----------|
| 3    | BRUSH-DRAW VALVE 1 X 2 X 17 | 013073   |
| 4    | BRUSH-MIX PUMP BODY- 3 X 7  | 023316   |

## Optional Carts

**Cart A.-ADA X69400  
C20600-AFB**

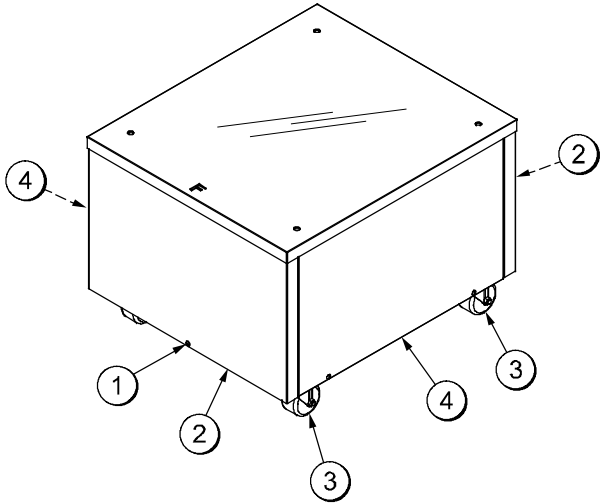

**Cart A.-Std. X69425  
C20600-000**

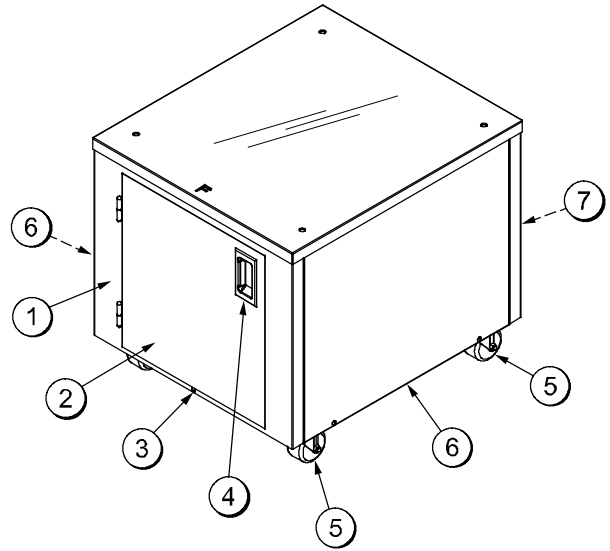

Figure 6

| ITEM | DESCRIPTION                       | PART NO. |
|------|-----------------------------------|----------|
|      | CART A.-ADA                       | X69400   |
| 1    | SCREW-10-32 X 1/2 SLTD            | 037734   |
| 2    | PANEL-FRONT/REAR-ADA              | 069402   |
| 3    | CASTER-3" SWV 3/4-10 STEM W/BRAKE | 030307   |
| 4    | PANEL-SIDE-CART                   | 069403   |

**NOTE:** THIS IS AN ADA COMPLIANT HEIGHT CART, NOT EQUIPPED WITH A DOOR.

| ITEM | DESCRIPTION                       | PART NO. |
|------|-----------------------------------|----------|
|      | CART A.-STD                       | X69425   |
| 1    | PANEL A.-STD CART-FRONT           | X69426   |
| 2    | DOOR A.-STD CART                  | X69295   |
| 3    | SCREW-10-32 X 1/2 SLTD TRUS       | 037734   |
| 4    | HANDLE-STNLS FLUSH PULL           | 019043   |
| 5    | CASTER-3" SWV 3/4-10 STEM W/BRAKE | 030307   |
| 6    | PANEL-SIDE-STD CART               | 069428   |
| 7    | PANEL-REAR-STD CART               | 069429   |

**NOTE:** THIS IS A STANDARD HEIGHT CART WITH REVERSIBLE FRONT DOOR PANEL AND REAR PANEL.

# Section 5

# Important: To the Operator

Model C722

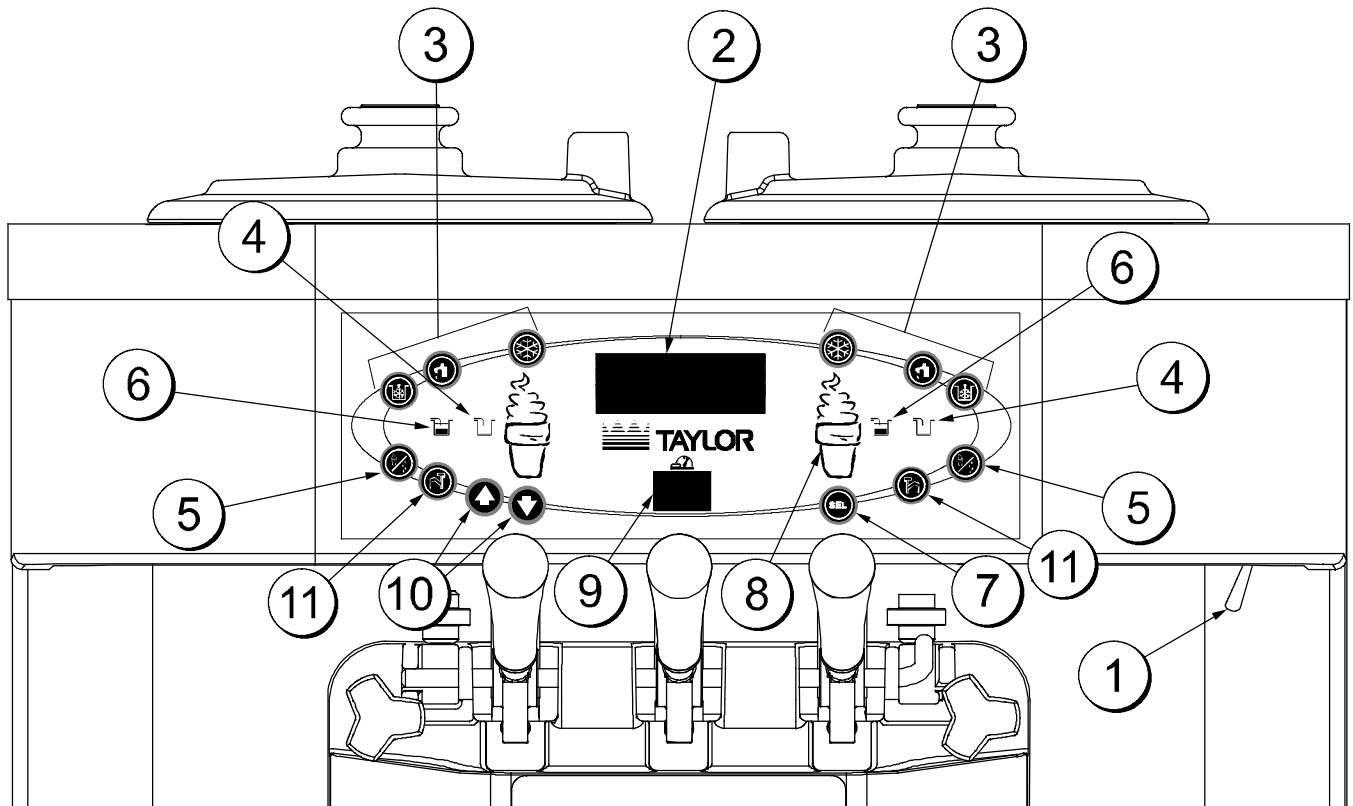

Figure 7

| ITEM | DESCRIPTION                          |
|------|--------------------------------------|
| 1    | POWER SWITCH                         |
| 2    | LIQUID CRYSTAL DISPLAY               |
| 3    | KEYPADS                              |
| 4    | MIX OUT INDICATORS                   |
| 5    | STANDBY INDICATORS                   |
| 6    | MIX LOW INDICATORS                   |
| 7    | SELECT KEY                           |
| 8    | SERVICE MENU KEY                     |
| 9    | BRUSH CLEAN COUNTER                  |
| 10   | ARROW KEYS                           |
| 11   | TOPPING HEATER KEYS (NOT FUNCTIONAL) |

## Symbol Definitions

To better communicate in the International arena, symbols have replaced words on many of our operator switches, function, and fault indicators. Your Taylor equipment is designed with these International symbols.

The following chart identifies the symbol definitions.

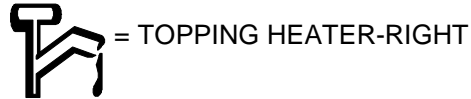
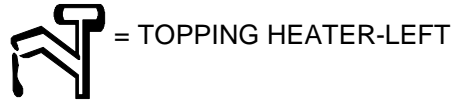
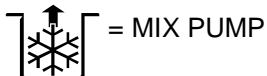
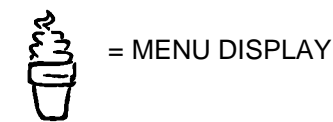
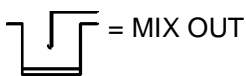
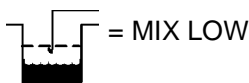
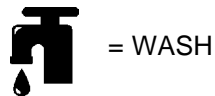
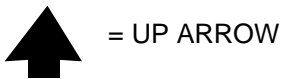
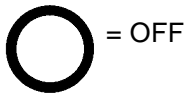
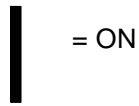

## Power Switch



When placed in the ON position, the power switch allows control panel operation.

## Fluorescent Display

The fluorescent display is located on the front control panel. During normal operation, the display is blank. The display is used to show menu options and notifies the operator if a fault is detected. On International models, the display will indicate the temperature of the mix in the hopper.

## Indicator Lights

**MIX LOW** - When the MIX LOW symbol  is illuminated, the mix hopper has a low supply of mix and should be refilled as soon as possible.

**MIX OUT** - When the MIX OUT  symbol is illuminated, the mix hopper has been almost completely exhausted and has an insufficient supply of mix to operate the freezer. At this time, the AUTO mode is locked out and the freezer will be placed in the STANDBY mode. To initiate the refrigeration system, add mix to the mix hopper and touch the AUTO symbol . The freezer will automatically begin operation.

**Optional feature:** Some freezers are equipped with rear indicator lights.

## Standby Symbol

During long “No Sale” periods, the unit can be placed into the Standby mode. This maintains product temperatures below 40°F (4.4°C) in both the hopper and the freezing cylinder, and helps prevent overbeating and product breakdown.

To activate Standby, select the STANDBY key or enter the access code for the Manager Menu and select the Standby Mode option (see pages 19 and 22). The STANDBY symbol  will illuminate, indicating the Standby feature has been activated.

**Note:** To resume normal operation, press the AUTO symbol . When the unit cycles off, the product in the freezing cylinder will be at serving viscosity.

## Wash Symbol

The WASH symbol  will illuminate when it is touched. This indicates beater motor operation. The STANDBY or AUTO modes must be cancelled first to activate the WASH mode.

## Auto Symbol

The AUTO symbol  will illuminate when it is touched. This indicates that the refrigeration system has been activated. In the AUTO mode, the WASH or STANDBY functions are automatically cancelled.

**Note:** An indicating light and an audible tone will sound whenever a mode of operation has been selected. To cancel any function, touch the key again. The light and the mode of operation will shut off.

## Topping Heater Symbols



The TOPPING HEATER symbols are not functional on the Model C722.

## Reset Mechanism

The reset buttons are located in the left side panel of the machine. They protect the beater motors from an overload condition. Should an overload occur, the reset mechanism will trip. To properly reset the freezer, place the power switch in the OFF position. Press the reset button firmly. Turn the power switch to the ON position. Touch the WASH symbol  and observe the freezer's performance.



**WARNING: Do not use metal objects to press the reset button.** Failure to comply may result in severe personal injury or death.

If the beater motor is turning properly, touch the WASH symbol  to cancel the cycle. Touch the AUTO symbol  to resume normal operation. If the freezer shuts down again, contact your authorized service technician.

## Adjustable Draw Handle

This unit features an adjustable draw handle to provide the best portion control, giving a better, consistent quality to your product and controlling costs. The draw handle should be adjusted to provide a flow rate of 5 to 7-1/2 oz. (142 to 213 g.) of product by weight per 10 seconds. To INCREASE the flow rate, tighten the screw. To DECREASE the flow rate, loosen the screw. (See Figure 8.)

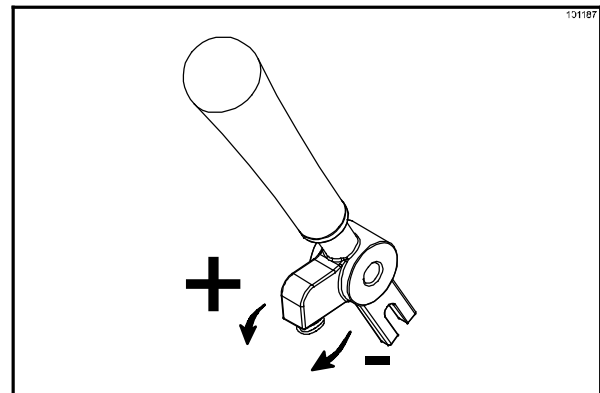

Figure 8

## Operating Screen Descriptions

The fluorescent display located in the center of the control panel is normally blank during the daily operation of the machine. The display is activated when the SEL symbol or the Manager's Menu is selected. The display screen will also alert the operator of specific faults detected by the control.

### Power Up

When the machine is powered, the control system will initialize to perform a system check. The screen will display "INITIALIZING". There are four types of data the system will check: LANGUAGE, SYSTEM DATA, CONFIG DATA, and LOCKOUT DATA.

If the system detects corrupt data during "Initializing....", the detected faults will be displayed for acknowledgement after the "SAFETY TIMEOUT" display, if the power switch is on. The faults may be "CORRUPTED LANGUAGE," "CONFIG CRC ERR," "SYSTEM CRC ERR," "FAULT HISTORY," "LOCKOUT CRC ERR," or "POWER FAILURE."

Once the system has initialized, the number of days remaining before the next required brush cleaning is indicated on the control panel and the SAFETY TIMEOUT screen is displayed with the alarm turned on. (See Figure 9.)

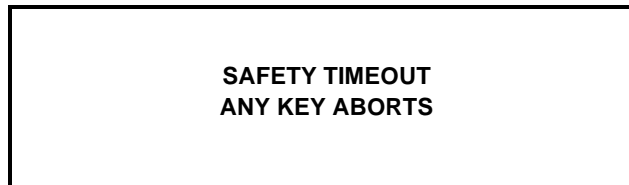

Figure 9

The SAFETY TIMEOUT screen will be displayed with the alarm on for 60 seconds, or until any control symbol is selected.

After the safety timeout has been completed and the power switch is OFF, the following screen is displayed. (See Figure 10.)

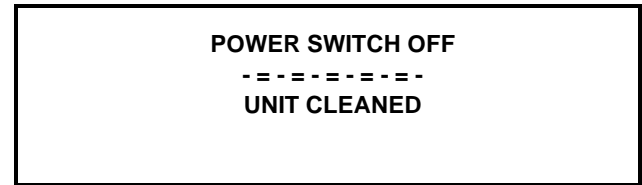

Figure 10

### Power Switch ON

When the power switch is placed in the ON position, the control panel touch keys become operative. The fluorescent display will be either blank or will indicate that the unit has been cleaned. (See Figure 11.)

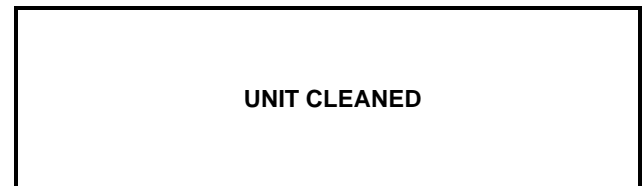



Figure 11

### Brush Clean Counter

The Brush Clean Counter (item 9 on page 15) will display the number of hours since the freezer was last brush cleaned. After hour 99, it will change to a letter and a number (example: A0, A1, ... B0, B1, etc.).

## Manager's Menu

The Manager's Menu is used to enter the operator function displays. To access the Menu, touch the center of the CONE symbol  on the control panel on the right side of the machine. The arrow symbols, the SEL symbol, and the CONE symbol  will be lit when the ACCESS CODE screen is displayed. (See Figure 12.)

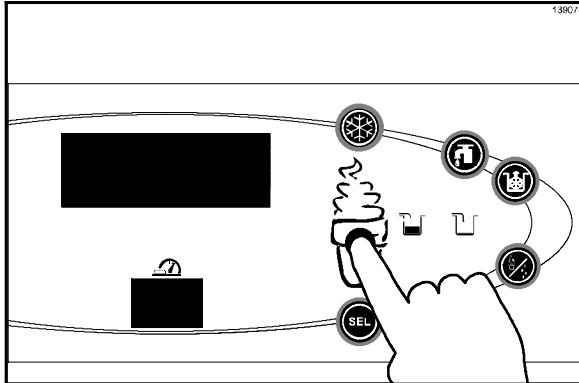

Figure 12

In the Menu program, the arrow symbols and the SEL symbol will function as menu keys.

**UP ARROW** - increases the value above the cursor and is used to scroll upward in text displays.

**DOWN ARROW** - decreases the value above the cursor and is used to scroll downward in text displays.

**SEL** - advances the cursor position to the right and is used to select menu options.

**Note:** The machine will continue operation in the mode it was in when the menu was selected. However, the control keys will not be lit and are non-functional when the Manager's Menu is displayed.

## Entering Access Code

With the ACCESS CODE screen on the display, use the SEL symbol to set the first code number in the cursor position. When the correct number is selected, touch the SEL symbol to move the cursor to the next number position. (See Figure 13.)

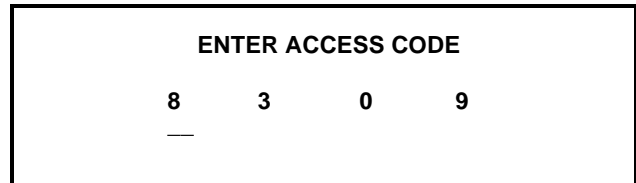

Figure 13

Continue to enter the proper access code numbers (8309) until all four numbers are displayed, and then touch the SEL symbol. The Manager's menu list will display on the screen, provided the correct access code is entered.

If an incorrect number is entered for the access code, the display will exit the Menu program when the SEL symbol is selected. (See Figure 14.)

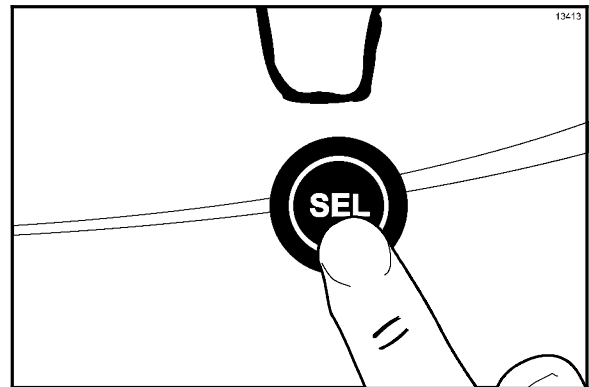



Figure 14

## Menu Options

Touch the ARROW symbols to move up or down through the Menu. Select a Menu option by touching the SEL symbol. Exit the Menu program by selecting EXIT FROM MENU or touch the CONE symbol .

The following menu options are listed in the Manager's Menu.

EXIT FROM MENU  
 SERVINGS COUNTER  
 SET CLOCK  
 AUTO START TIME  
 STANDBY MODE  
 MIX LEVEL AUDIBLE  
 FAULT DESCRIPTION  
 FAULT HISTORY  
 LOCKOUT HISTORY  
 SYSTEM INFORMATION  
 CURRENT CONDITIONS  
 NET SERVICE PIN

Selecting "EXIT FROM MENU" will exit the Manager's Menu and then return the control panel symbols to normal operation.

The SERVINGS COUNTER screen is used to reset the servings counter to zero. (Note: The SERVINGS COUNTER automatically resets to zero when the machine is brush cleaned.) (See Figure 15.)

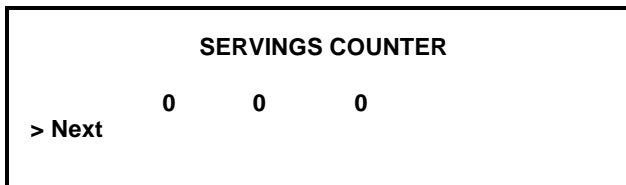

Figure 15

Reset the SERVINGS COUNTER by selecting the SEL symbol to advance to the next screen. Select the UP arrow symbol to move the arrow (>) to YES and touch the SEL symbol. The servings counter will reset to zero and exit back to the Manager's Menu. (See Figure 16.)

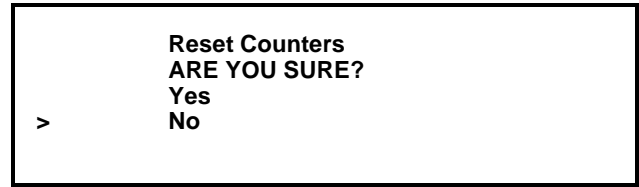

Figure 16

The SET CLOCK option allows the Manager to adjust the control clock date and time. The date and time may only be changed after the freezer has been manually cleaned, but before it has been placed in the AUTO or STANDBY mode. The following message will be displayed if the SET CLOCK option is selected when the machine is not in a brush clean state. (See Figure 17.)



Figure 17

To change the date or time, select the SET CLOCK option in the menu. Touch the UP arrow symbol to advance the arrow from "Exit" to "Change", and then touch the SEL symbol to select the Change option. (See Figure 18.)



Figure 18

Change the time by touching the UP arrow with the cursor under the hour position. Move the cursor to the minutes position by touching the SEL symbol. Once the correct minutes are entered, touch the SEL symbol to advance the cursor to the month. (See Figure 19.)



Figure 19



Enter the correct month, day, and year. After they have been entered, touch the SEL symbol to advance to the DAYLIGHT SAVING TIME (DST) screen. (See Figure 20.)



Figure 20

Pressing the UP or DOWN arrow symbols will move the arrow to “Enable” or “Disable”. Pressing the SEL symbol next to “Disable” selects that option and returns to the Manager Menu. Pressing the SEL symbol next to “Enable” selects that option and displays the second screen. (See Figure 21.)

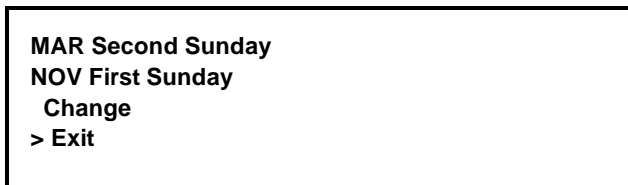

Figure 21

If the correct Sunday for the time change is not displayed, then “Change” should be selected. Pressing the SEL symbol with the arrow next to “Change” displays the third screen. Press the UP or DOWN symbol to move the arrow to the appropriate month for the start of DST. (See Figure 22.)

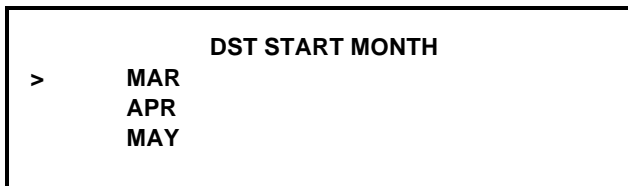

Figure 22

Pressing the SEL symbol with the arrow next to the appropriate month will display the following screen. (See Figure 23.)



Figure 23

Pressing the UP or DOWN symbol will move the arrow to the appropriate week for the start of DST. Pressing the SEL symbol next to the appropriate week will display the following screen. Press the UP or DOWN symbol to move the arrow to the appropriate month for the end of DST. (See Figure 24.)



Figure 24

Pressing the SEL symbol next to the appropriate month will display the following screen. Press the UP or DOWN symbol to move the arrow to the appropriate week for the end of DST. (See Figure 25.)

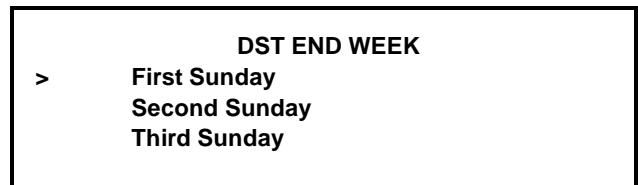

Figure 25

Pressing the SEL symbol with the arrow by the appropriate week will select that setting and return to the Manager's Menu.

The AUTO START TIME option allows the Manager to set the time of day at which the machine automatically enters the AUTO mode from the STANDBY mode. The machine must be in the STANDBY mode in order to AUTO start at the programmable time. The AUTO START TIME can also be disabled and require starting the AUTO mode manually. (See Figure 26.)



Figure 26

Enable the AUTO START TIME by selecting the UP arrow symbol to move the arrow to “Enable.” Touch the SEL symbol to advance to the next screen. (See Figure 27.)

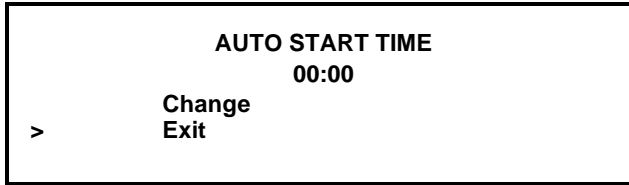

Figure 27

Program the AUTO START TIME by selecting the UP arrow symbol to move the arrow to “Change.” Touch the SEL symbol to advance to the next screen. (See Figure 28.)

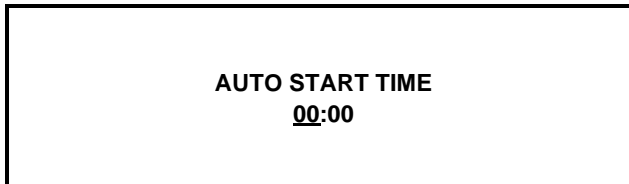

Figure 28

Use the arrow symbols to program the AUTO START TIME by increasing or decreasing the hour setting above the cursor. Touch the SEL symbol to advance the cursor and program the minutes setting. Select the SEL symbol to return to the previous screen with the new time setting displayed. Select the SEL symbol to exit the screen and return to the Manager's Menu.

The STANDBY option is used to manually place either side of the machine in the Standby mode during long, no draw periods. Select the STANDBY screen from the Menu. Touch the SEL symbol to activate Standby.

Discontinue Standby operation by exiting the Manager's Menu and selecting the AUTO mode. (See Figure 29.)

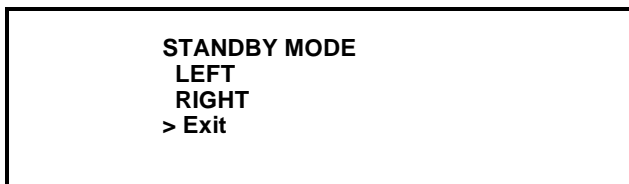

Figure 29

The MIX LEVEL AUDIBLE option, when enabled, will alert the operator with an audible tone when there is a mix low or mix out condition. The following screen is displayed upon selecting this option. (See Figure 30.)

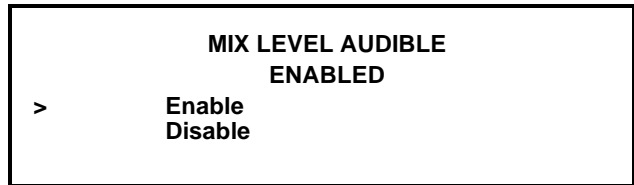

Figure 30

Disable the audible tone feature by selecting the DOWN arrow symbol to move the arrow to “Disable.” Select the SEL symbol to save the new setting and return to the Manager's Menu. The control panel icons for Mix Low and Mix Out will light as the mix level drops in the hopper but the audible tone will be disabled.

The FAULT DESCRIPTION screen lists any faults detected by the control and allows the Manager to clear them from the system. Faults are displayed on the second and/or third line. (See Figure 31.)

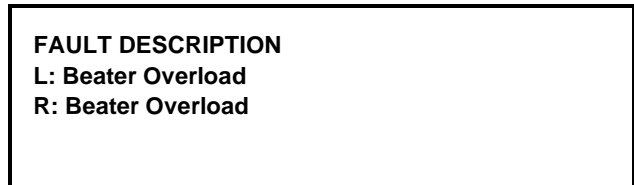

Figure 31

Pressing the SEL symbol displays the next fault or returns to the Manager's Menu if no other faults exist. Pressing the SEL symbol any time faults are displayed will clear corrected faults upon returning to the Manager's Menu. Press the Menu symbol to return to the Manager's Menu.

The FAULT HISTORY screen displays a history of the last 100 faults. Page numbers are displayed in the upper right-hand corner. Page 1 contains the most recent fault. Use the arrow symbols to cycle through the history pages. The date and time of the event are displayed on the second line. The third line displays the reason for the fault. (See Figure 32.)

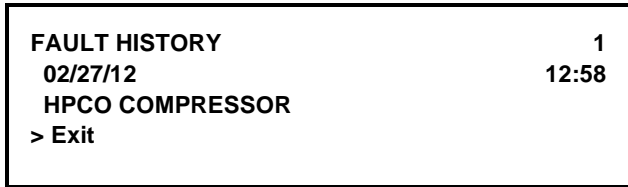

Figure 32

The LOCKOUT HISTORY screen displays a history of the last 100 hardlocks, brush clean dates, etc. (See Figure 33.)

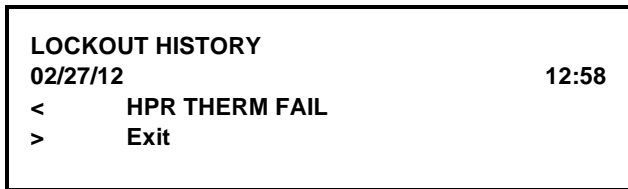

Figure 33

Use the arrow symbols to advance forward or backward to view each screen. The following list indicates the variable messages that may appear. Press the SEL key to return to the Manager's Menu.

**Note:** If no fault was found, the message will state, "NO FAULT FOUND".

## Faults Occurring While in AUTO or Standby Mode

**BEATER OVERLOAD** - Place the power switch in the OFF position. Wait 5 minutes for the machine to cool. Press the beater reset button firmly. Place the power switch in the ON position and restart in AUTO.

**HPCO COMPRESSOR** - Place the power switch in the OFF position. Wait 5 minutes for the machine to cool. Place the power switch in the ON position and restart in AUTO.

**L - R HPR Therm Fail** - The hopper thermistor failed. Call for service.

**L - R BRL Therm Fail** - The freezing cylinder thermistor failed. Call for service.

**L - R HPR>59F (15C)** - The mix temperature in the hopper exceeded 59°F (15°C).

**L - R BRL>59F (15C)** - The mix temperature in the freezing cylinder exceeded 59°F (15°C).

**L - R HPR>45F (7C) AFTER 1 HR** - The mix temperature in the hopper was above 45°F (7°C) more than one hour.

**L - R BRL>45F (7C) AFTER 1 HR** - The mix temperature in the freezing cylinder was above 45°F (7°C) more than one hour.

**L - R HPR>41F (5C) AFTER 4 HR** - The mix temperature in the hopper was above 41°F (5°C) more than four hours.

**L - R BRL>41F (5C) AFTER 4 HR** - The mix temperature in the freezing cylinder was above 41°F (5°C) more than four hours.

**L - R HPR>41F (5C) AFTER PF** - The mix temperature in the hopper was above 41°F (5°C) more than four hours, following a power failure.

**L - R BRL>41F (5C) AFTER PF** - The mix temperature in the freezing cylinder was above 41°F (5°C) more than four hours, following a power failure.

**Note:** Refer to your local health codes regarding temperature recommendations for procedures to follow if these fault screens appear.

The SYSTEM INFORMATION is displayed on three separate screens. The first screen contains the control and software version installed in the machine. (See Figure 34.)

```
SOFTWARE VERSION
C722 CONTROL UVC4
VERSION V00.00.000
> Next
```

Figure 34

Touch the SEL symbol to advance to the next system information screen containing the software language version. (See Figure 35.)

```
Language
V4.00 English
> Next
```

Figure 35

Touch the SEL symbol to advance to the third system information screen containing the model bill of material and machine serial number. Touching the SEL symbol again will return to the Manager's Menu. (See Figure 36.)

```
B.O.M. C700000000
S/N K0000000
> Next
```

Figure 36

The CURRENT CONDITIONS screen displays the current viscosity, and the hopper and barrel temperatures. Press the SEL or MENU symbols to return to the Manager's Menu. (See Figure 37.)

```
VISC          0.0    0.0
HOPPER        41.0   41.0
BARREL        41.0   41.0
```

Figure 37

The NET SERVICE PIN screens allows the Manager to initialize a network connection for networking kitchens. (See Figure 38.)

```
NET SERVICE PIN
ARE YOU SURE?
Yes
> No
```

Figure 38

Use the arrow symbols to move the arrow up or down. Pressing the SEL symbol with the arrow next to "No" will return to the Manager's Menu. Pressing the SEL symbol with the arrow next to "Yes" will connect to the network if a gateway card is connected.

**Note:** If "Yes" is selected, it may take a few moments for the memory to clear and the defaults to load. The display may show the message "COMMUNICATIONS FAILURE" during this time.

# Section 6

# Operating Procedures

The Model C722 is a medium capacity soft serve machine. Mix is stored in the hoppers. The unit is equipped with a three spout door and two 2.8 quart (2.7 liter) capacity freezing cylinders.

We begin our instructions at the point where we enter the store in the morning and find the parts disassembled and laid out to air dry from the previous night's cleaning.

These opening procedures will show you how to assemble the parts into the freezer, sanitize them, and prime the freezer with fresh mix in preparation to serve your first portion.

If you are disassembling the machine for the first time or need information to get to this starting point in our instructions, turn to page 36, "Disassembly", and start there.

## Assembly

**Note:** When lubricating parts, use an approved food grade lubricant (example: Taylor Lube).



**MAKE SURE THE POWER SWITCH IS IN THE "OFF" POSITION!** Failure to follow this instruction may result in severe personal injury from hazardous moving parts.

### Step 1

Lubricate the groove on the beater drive shaft.

### Step 2

Slide the beater drive shaft boot seal over the small end of the beater drive shaft and engage into the groove on the shaft.

### Step 3

Heavily lubricate the inside portion of the boot seal. Also lubricate the flat end of the boot seal that comes in contact with the rear shell bearing.

### Step 4

Apply an even coat of lubricant to the shaft. **DO NOT lubricate the hex end.**

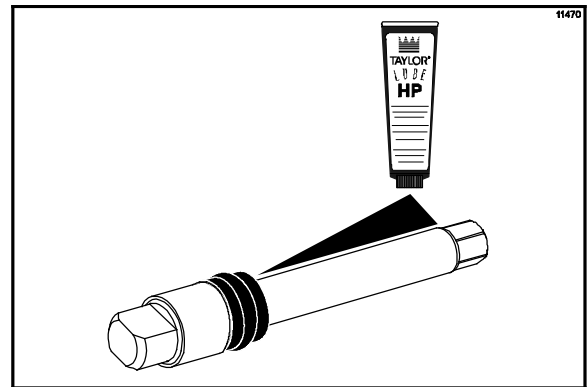

Figure 39

**Note:** To ensure that mix does not leak out of the back of the freezing cylinder, the middle section of the boot seal should be convex or extend out from the seal. If the middle section of the boot seal is concave or extending into the middle of the seal, turn the seal inside out.

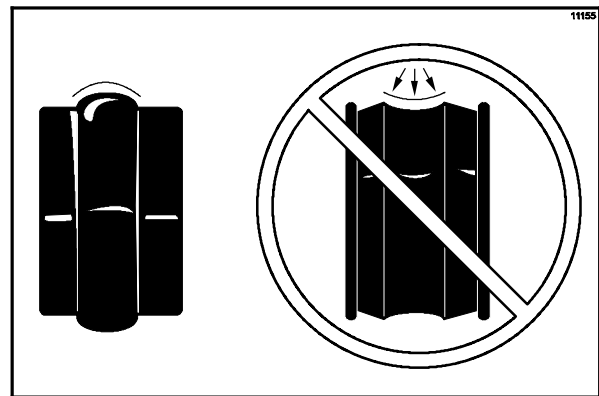

Figure 40

### Step 5

Insert the beater drive shaft through the rear shell bearing in the freezing cylinder and engage the hex end firmly into the drive coupling.

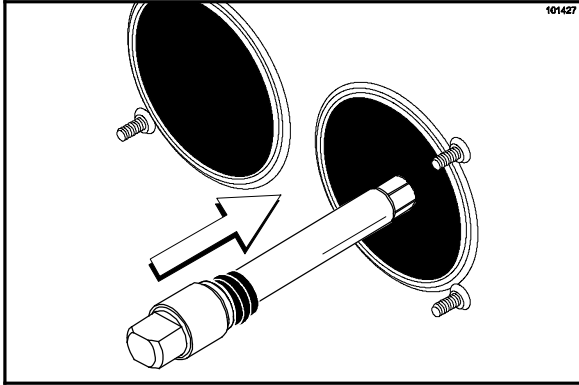

Figure 41



**USE EXTREME CAUTION** when handling the beater assembly. The scraper blades are very sharp and may cause injury.

### Step 6

Before installing the beater assembly, check the scraper blades and clips.

Check the scraper blades for any signs of wear or damage. If a scraper blade is nicked or worn, replace both blades.

Check the scraper blade clips to make sure they are not bent and the slot is even for the entire length of the clip. Replace any damaged clips.

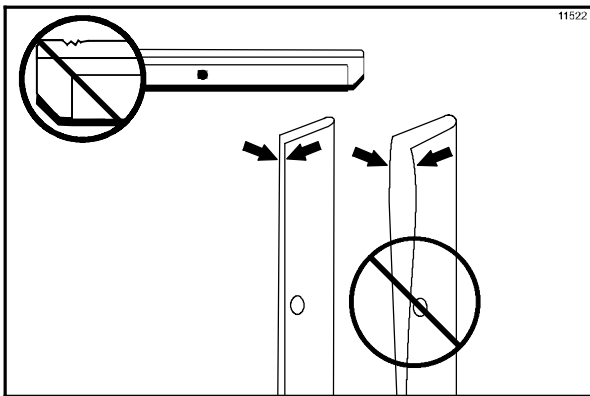

Figure 42

If the blades and clips are in good condition, install the scraper blade clips over the scraper blades. Place the rear scraper blade over the rear holding pin on the beater.

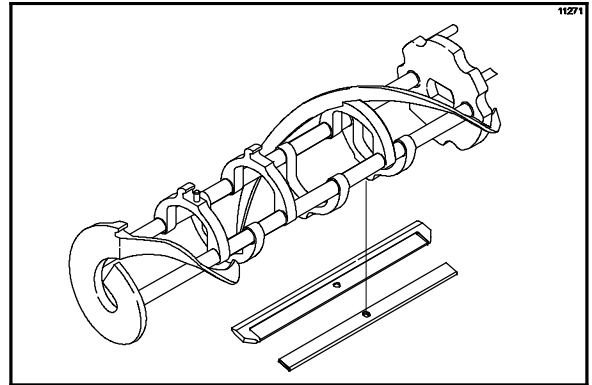

Figure 43

**Note:** Scraper blades should be replaced every 3 months.

**Note:** The hole on the scraper blade must fit securely over the pin to prevent costly damage.

### Step 7

Holding the rear blade on the beater, slide it into the freezing cylinder halfway. Install the front scraper blade over the front holding pin.

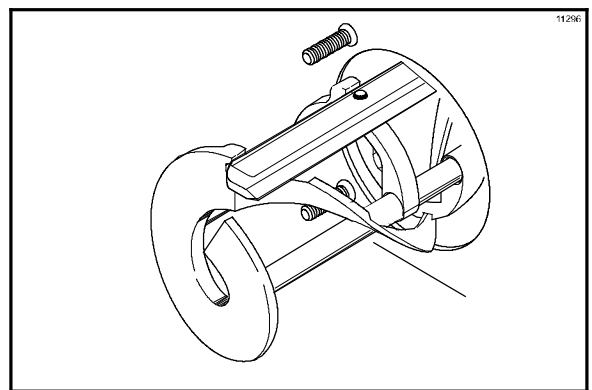

Figure 44

### Step 8

Before installing the beater shoes, check the shoes for any nicks, cracks, or signs of wear. If any defects are present, replace the beater shoes.

### Step 9

If the beater shoes are in good condition, install the beater shoes.

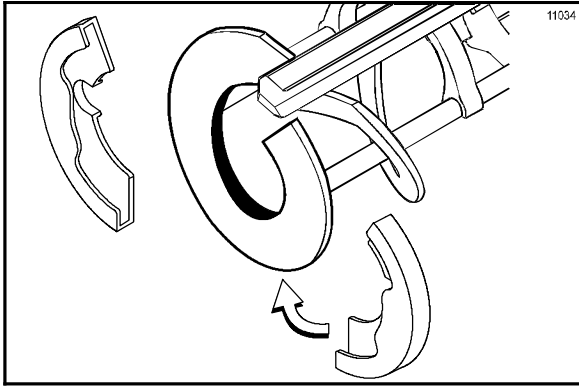

Figure 45

### Step 10

Slide the beater assembly the rest of the way into the freezing cylinder.

Make sure the beater assembly is in position over the drive shaft by turning the beater slightly until the beater is properly seated. When in position, the beater will not protrude beyond the front of the freezing cylinder.

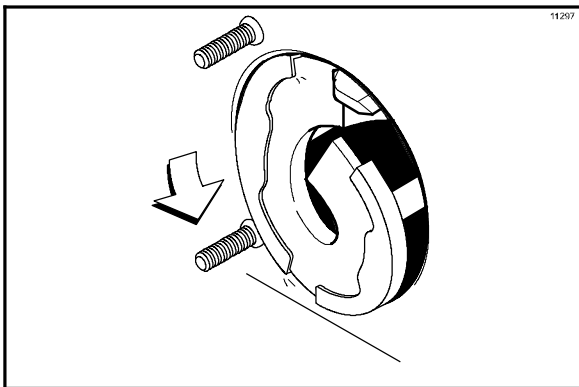

Figure 46

Repeat these steps for the other side of the machine.

### Step 11

Before assembling the freezer door, check the following for any nicks, cracks, or signs of wear: door bearings, door gaskets, draw valves, o-rings, and all sides of the door assembly, including the inside of the draw valve bores. Replace any damaged parts.

### Step 12

Place the door gaskets into the grooves on the back of the freezer door. Do not lubricate the gaskets.

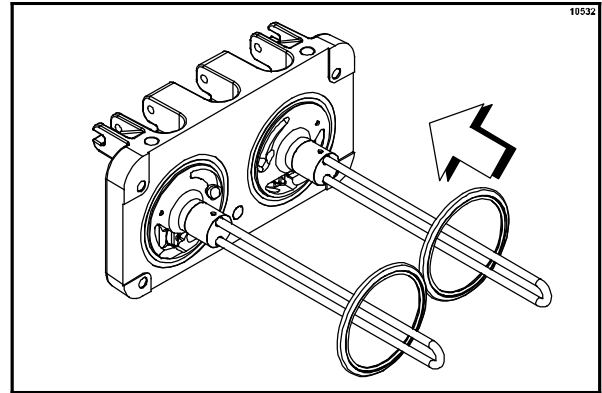
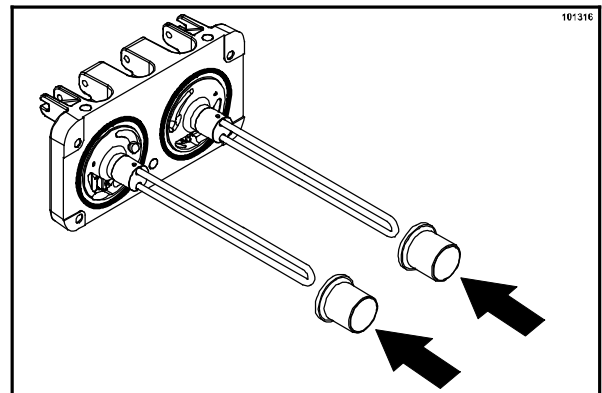

Figure 47

### Step 13

Slide the front bearings over the baffle rods. The flanged edges should be against the door. **DO NOT lubricate the gaskets or front bearings.**



Slide the two o-rings into the grooves on each prime plug. Apply an even coat of Taylor Lube to the o-rings and shafts.

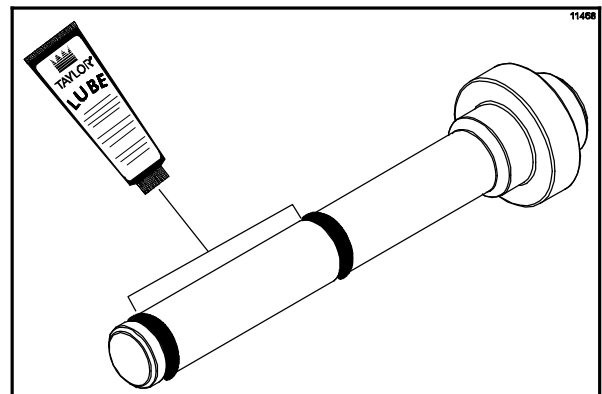

Figure 48

**Step 14**

Insert the prime plugs into the holes in the top of the freezer door, and push down.

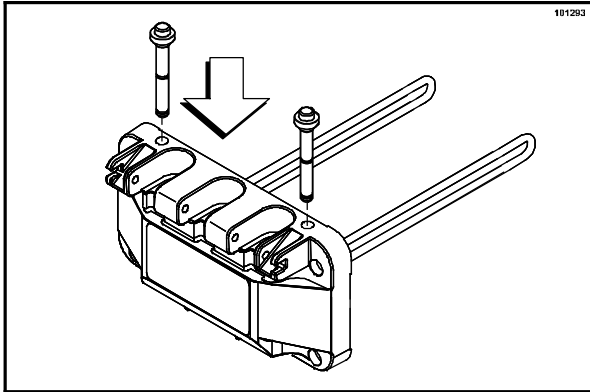

Figure 49

**Step 15**

To install the freezer door, insert the baffle rods through the beaters in the freezing cylinders.

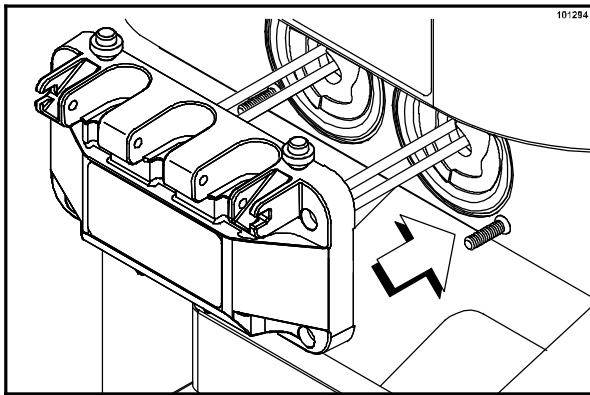

Figure 50

With the door seated on the freezer studs, install the handscrews. Use the long handscrews on the top and the short handscrews on the bottom. Tighten them equally in a criss-cross pattern to insure the door is snug.

**Step 16**

Slide the three o-rings into the grooves of each standard draw valve. Slide the H-ring and o-ring into the grooves of the center draw valve. Lubricate the H-ring and o-rings.

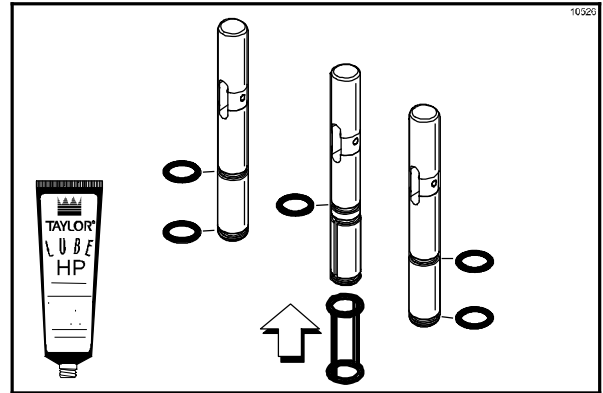

Figure 51

**Step 17**

Lubricate the inside of the freezer door spouts, top and bottom.

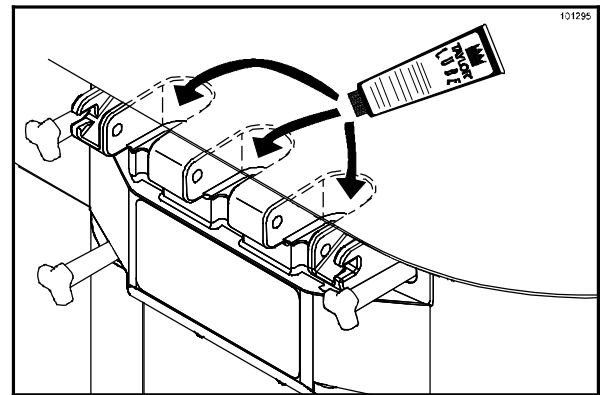

Figure 52

**Step 18**

Insert the draw valves from the bottom until the slot in each draw valve comes into view.

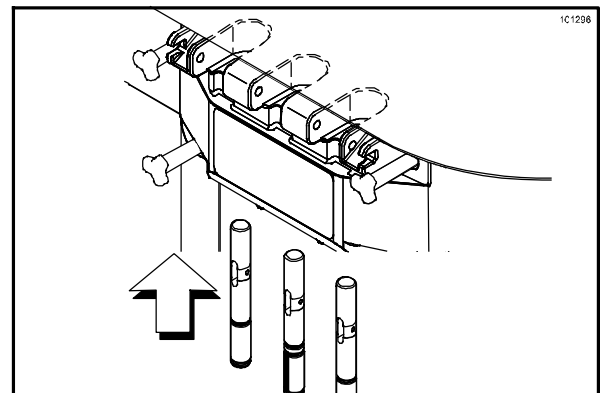

Figure 53



**Step 19**

Position each draw handle with the adjustment screw facing down. Slide the fork of each draw handle into the slot of each draw valve, starting from the right.

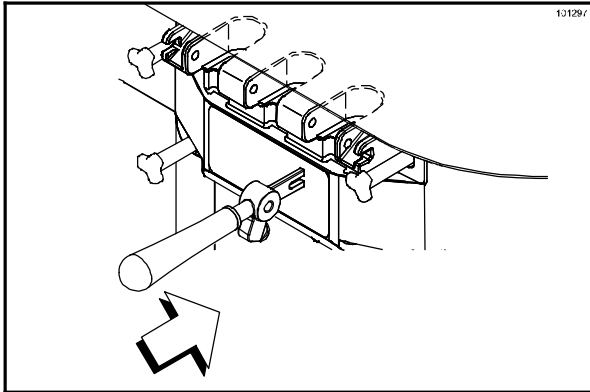

Figure 54

**Step 20**

Slide the pivot pin through the draw handles as the handles are inserted into the draw valves.

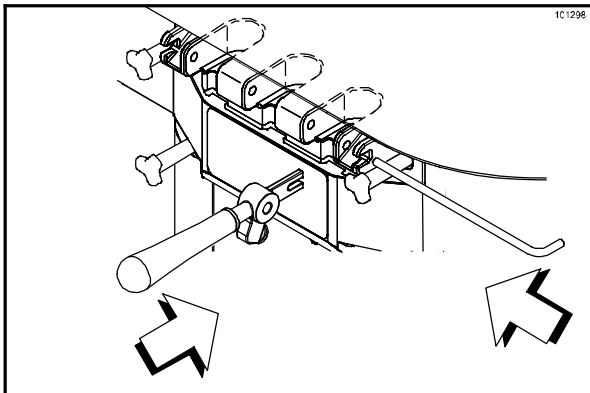

Figure 55

**Note:** This freezer features three adjustable draw handles to provide portion control, giving a better consistent quality to your product and controlling costs. The draw handle should be adjusted to provide a flow rate of 5 to 7-1/2 oz. (142 g. to 213 g.) of product by weight per 10 seconds.

To INCREASE the flow rate, tighten the screw. To DECREASE the flow rate, loosen the screw.

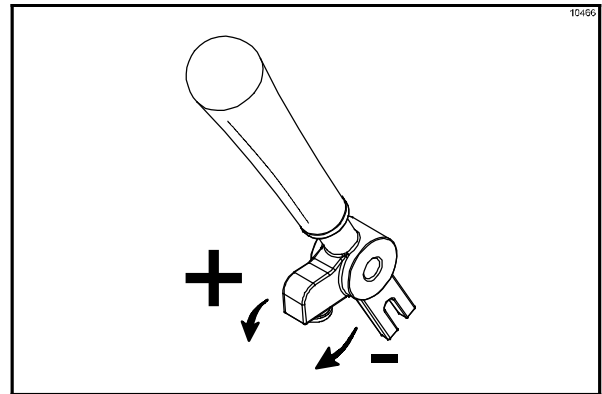

Figure 56

**Step 21**

Snap the design caps over the bottom of the door spouts.

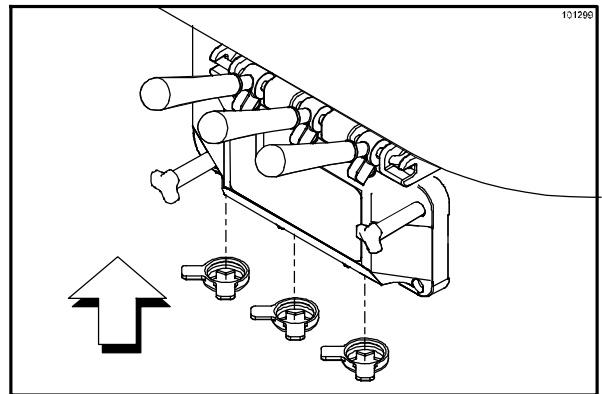

Figure 57

**Step 22**

Slide the drip pan into the hole in the front panel.

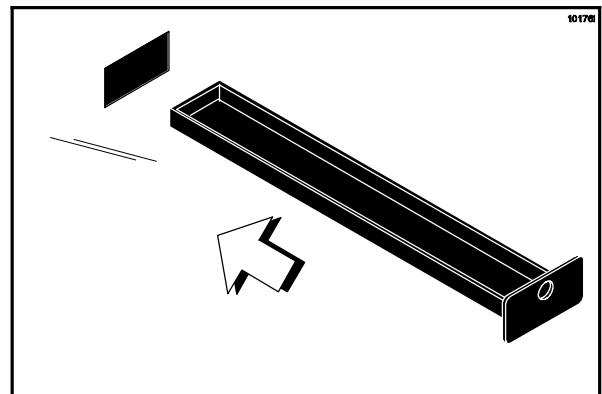

Figure 58

### Step 23

Install the front drip tray and splash shield under the door spouts.

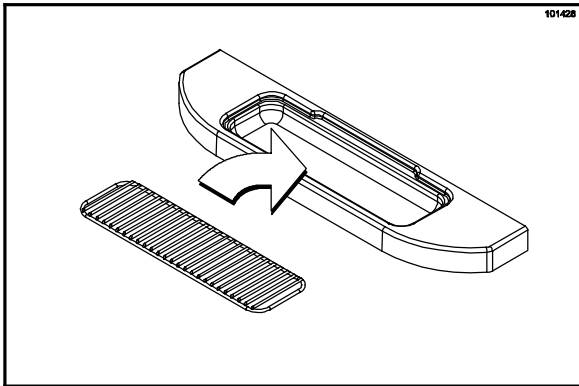

Figure 59

## Mix Pump Assembly

### Step 1

Inspect the rubber pump parts. O-rings and gasket must be in 100% good condition for the pump and entire machine to operate properly. The o-rings and gasket cannot properly serve their intended function if nicks, cuts, or holes in the material are present.

Inspect the plastic pump parts for cracks, wear, and de-lamination of plastic.

Replace any defective parts immediately and discard the old.

### Step 2

Assemble the piston. Slide the red o-ring into the groove of the piston. DO NOT lubricate the o-ring.

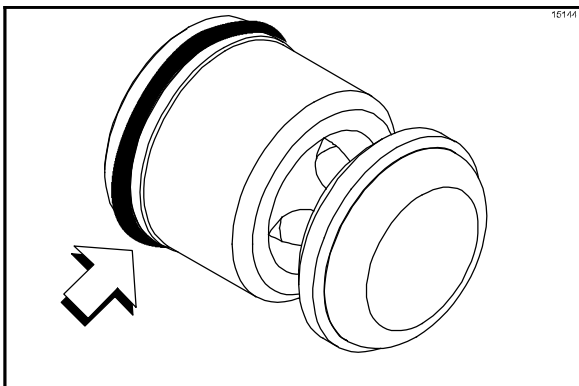

Figure 60

### Step 3

Apply a thin layer of lubricant to the inside of the pump cylinder at the retaining pin hole end.

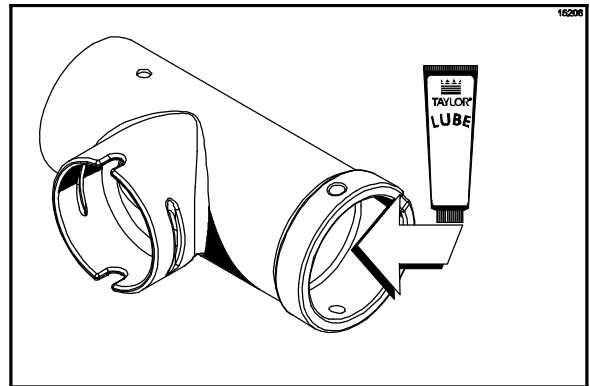

Figure 61

### Step 4

Insert the piston into the retaining pin hole end of the pump cylinder.

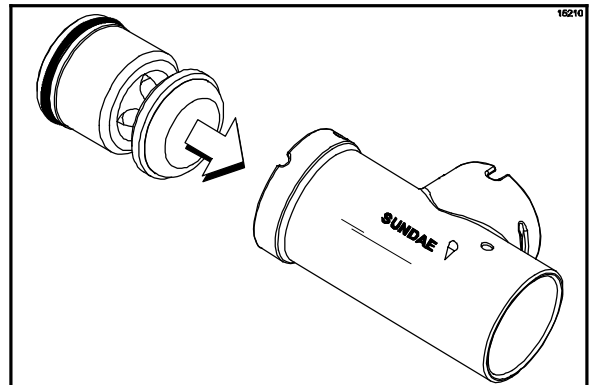

Figure 62

### Step 5

Assemble the valve cap. Slide the o-ring into the groove of the valve cap. DO NOT lubricate the o-ring.

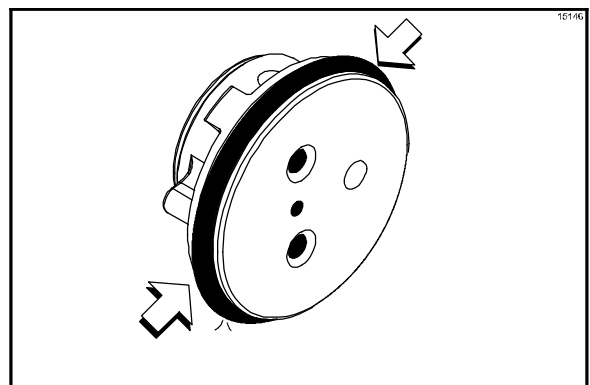

Figure 63

**Step 6**

Slide the pump valve gasket into the holes on the cap. DO NOT lubricate the gasket.

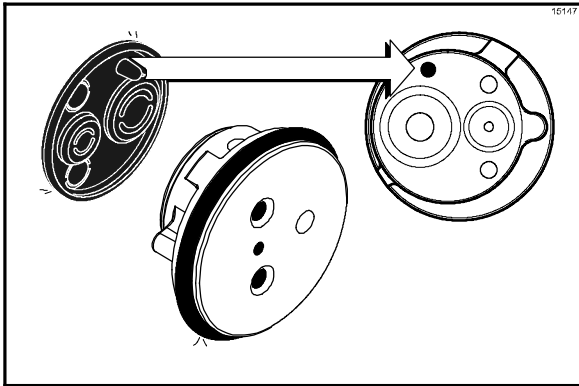

Figure 64

**Step 7**

Insert the valve body cap into the hole in the mix inlet adapter.

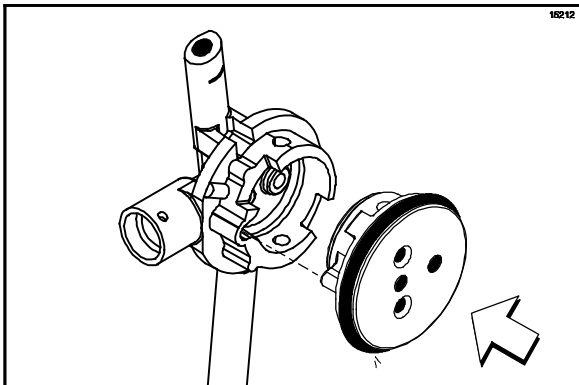

Figure 65

**Step 8**

Insert the mix inlet assembly into the pump cylinder.

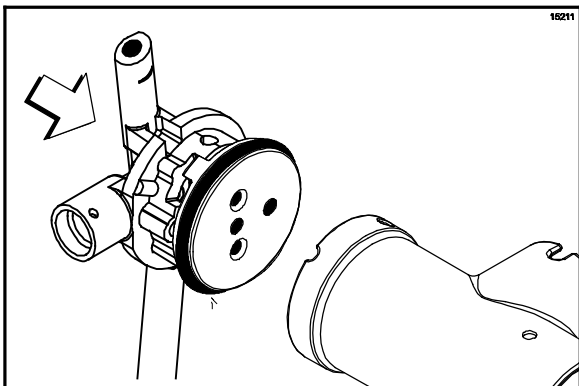

Figure 66

The adapter must be positioned into the notch located at the end of the pump cylinder.

**Step 9**

Secure the pump parts in position by sliding the retaining pin through the cross holes located at one end of the pump cylinder.

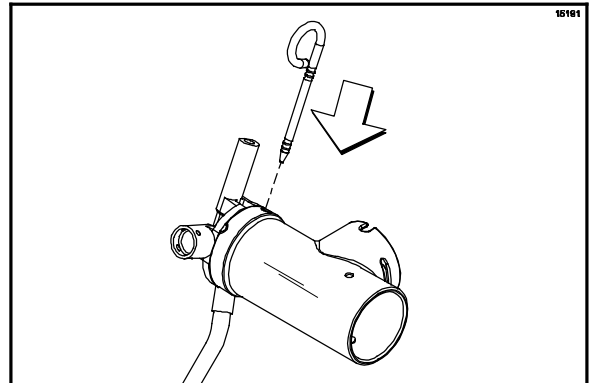

Figure 67

**Note:** The head of the retaining pin should be located at the top of the pump when installed.

**Step 10**

Assemble the feed tube assembly. Slide the check ring into the groove of the feed tube.

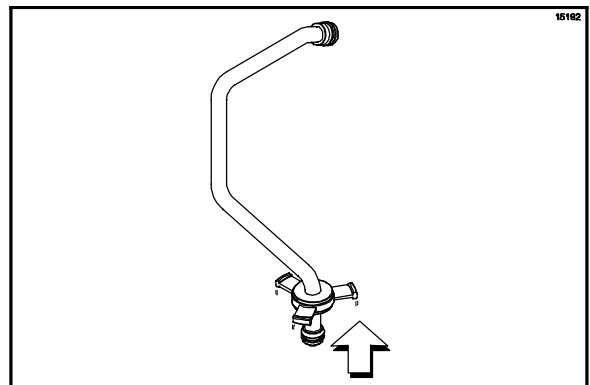

Figure 68

### Step 11

Install one red o-ring on each end of the mix feed tube, and thoroughly lubricate.

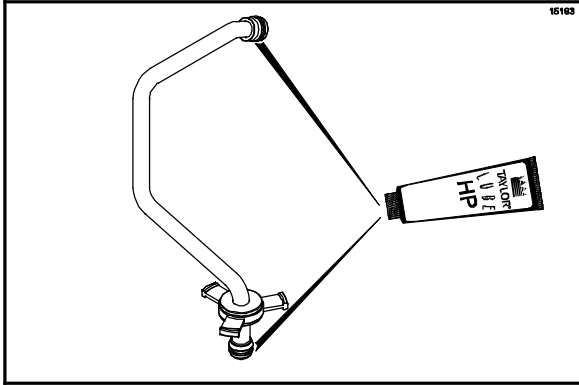

Figure 69

### Step 12

Lay the pump assembly, pump clip, cotter pin, mix feed tube, and the agitator in the bottom of the mix hopper for sanitizing.

### Step 13

Slide the large black o-ring and the two smaller black o-rings into the grooves on the drive shaft. Thoroughly lubricate the o-rings and shaft. **DO NOT** lubricate the hex end of the shaft.

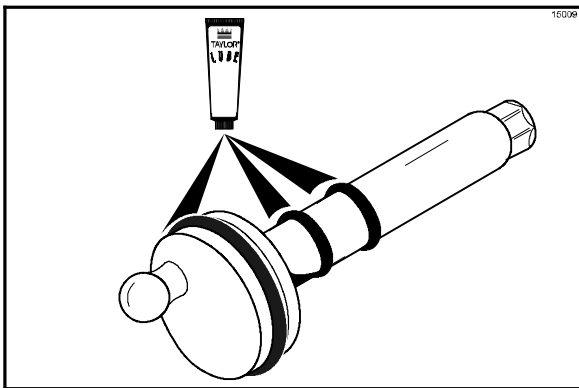

Figure 70

### Step 14

Install the hex end of the drive shaft into the drive hub at the rear wall of the mix hopper.

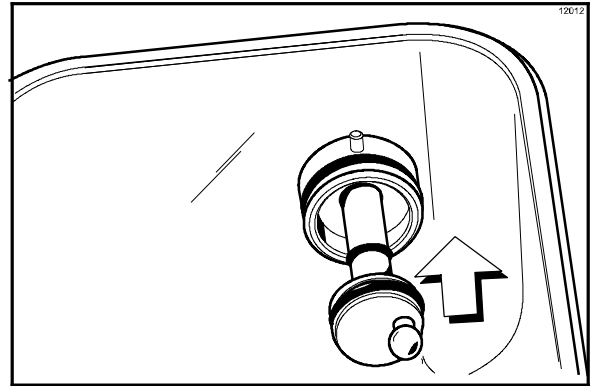

Figure 71

**Note:** For ease in installing the pump, position the ball crank of the drive shaft in the 3 o'clock position.

**Repeat these steps for the other side of the machine.**

## Sanitizing

### Step 1

Prepare a pail of cleaning/sanitizing solution with an active chlorine concentrate of 100 - 200 PPM (parts per million). **USE WARM WATER AND FOLLOW THE MANUFACTURER'S SPECIFICATIONS.**

### Step 2

Pour sanitizing solution over all the parts in the bottom of the mix hopper and allow it to flow into the freezing cylinder.

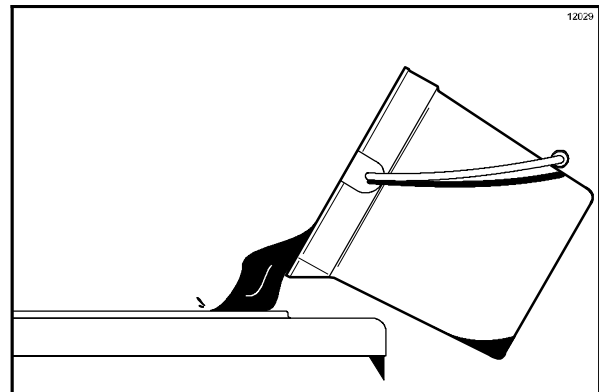

Figure 72

**Note:** You have just sanitized the mix hopper and parts; therefore, be sure your hands are clean and sanitized before proceeding with these instructions.

### Step 3

While the solution is flowing into the freezing cylinder, take particular care to brush-clean the mix level sensing probe, the mix hopper, the mix inlet hole, the air/mix pump, the pump clip, the mix feed tube, the cotter pin, and the agitator.

### Step 4

Install the pump assembly at the rear of the mix hopper. To position the pump on the drive hub, align the drive hole in the piston with the drive crank of the drive shaft. Secure the pump in place by slipping the pump clip over the collar of the pump, making sure the clip fits into the grooves in the collar. (See Figure 73.)

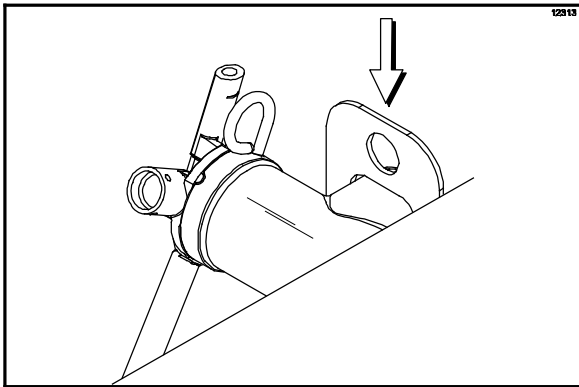

Figure 73

### Step 5



**Install the pump end of the mix feed tube and secure with the cotter pin. Failure to follow this instruction could result in sanitizer spraying on the operator. (See Figure 74.)**

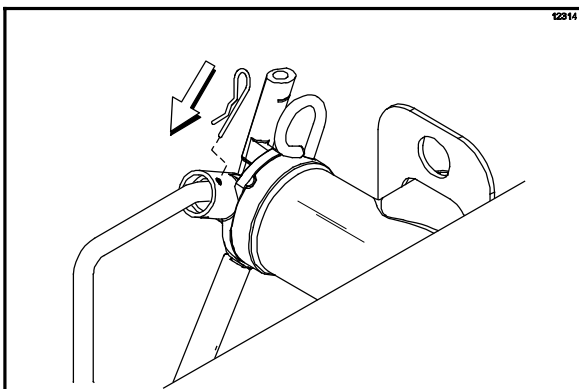

Figure 74

### Step 6

Prepare another pail of cleaning/sanitizing solution with an active chlorine concentrate of 100 - 200 PPM. USE WARM WATER AND FOLLOW THE MANUFACTURER'S SPECIFICATIONS.

### Step 7

Pour the sanitizing solution into the mix hopper.

### Step 8

Brush the exposed sides of the hopper.

### Step 9

Place the power switch in the ON position.

### Step 10

Touch the WASH symbol . This will cause the sanitizing solution in the freezing cylinder to be agitated. Wait at least 5 minutes before proceeding with these instructions.



### Step 11

With an empty pail beneath the door spouts, raise the prime plug and touch the PUMP symbol .

### Step 12

When a steady stream of sanitizing solution is flowing from the prime plug opening in the bottom of the freezer door, open the draw valve. Momentarily open the center draw valve to sanitize the center door spout. Draw off the remaining sanitizing solution.

### Step 13

Once the sanitizer stops flowing from the door spout, touch the WASH and PUMP symbols   and close the draw valve.

**IMPORTANT! The unit must NOT be placed in AUTO until all sanitizing solution has been removed from the freezing cylinder and proper priming procedures have been completed. Failure to follow this instruction may result in damage to the freezing cylinder.**

**Note: Be sure your hands are clean and sanitized before proceeding with these instructions.**

#### Step 14

Place the agitator on the agitator drive shaft housing.

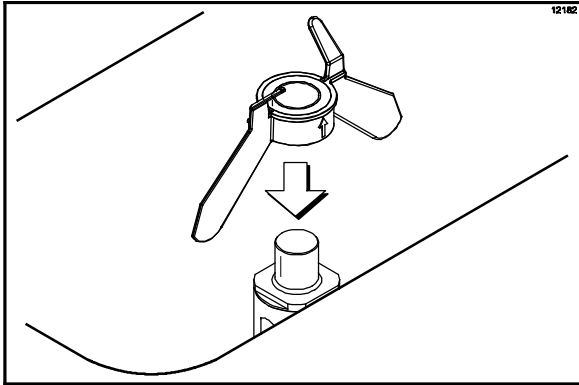

Figure 75

**Note:** If the agitator should stop turning during normal operation, with **sanitized hands**, remove agitator from agitator drive shaft housing and brush clean with sanitizing solution. Install the agitator back onto the agitator drive shaft housing.

**Repeat these steps for the other side of the machine.**

## Priming

**Note:** Use only **FRESH MIX** when priming the freezer.

#### Step 1

Place an empty pail beneath the door spouts. With the prime plug in the UP position, pour 2-1/2 gallons (9.5 liters) of **FRESH** mix into the mix hopper and allow it to flow into the freezing cylinder.

#### Step 2

Open the draw valve to remove all sanitizing solution. When only fresh mix is flowing, close the draw valve.

#### Step 3

Once a steady stream of mix starts to flow from the prime plug opening in the bottom of the freezer door, push the prime plug down.

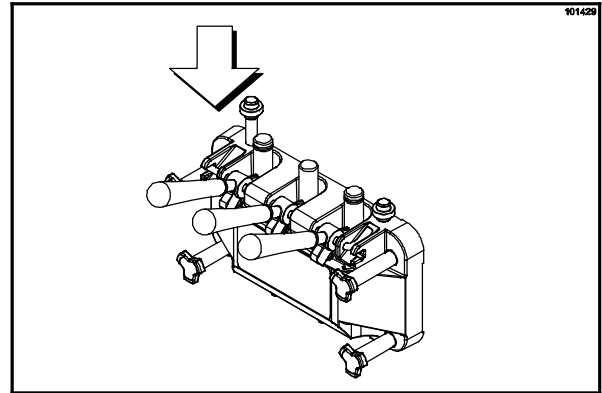

Figure 76

**IMPORTANT! Failure to remove all sanitizing solution may result in damage to the freezing cylinder.**

#### Step 4

When mix stops bubbling down into the freezing cylinder, remove the cotter pin from the outlet fitting of the mix pump. Insert the outlet end of the mix feed tube into the mix inlet hole in the mix hopper. Place the inlet end of the mix feed tube into the outlet fitting of the mix pump. Secure with cotter pin.

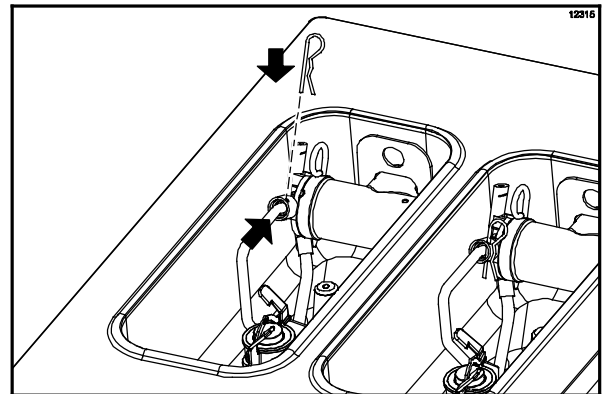

Figure 77

#### Step 5

Select the AUTO symbol ❄.

**Note:** The brush clean counter will start at this time.

#### Step 6

Fill the hopper with fresh mix and place the mix hopper cover in position.

**Repeat these steps for the other side of the machine.**

## Manual Brush Cleaning

This Procedure Must Be Completed Every Day





To disassemble the Model C722, the following items will be needed:

- Two cleaning and sanitizing pails
- Sanitizer/Cleaner
- Necessary brushes (provided with freezer)
- Single service towels

## Draining Product From The Freezing Cylinder



### Step 1

With a pail beneath the door spouts, open the draw valve. Touch the WASH and PUMP symbols  .

**IMPORTANT! DO NOT allow the pump to keep running when the draw valve is closed. Excessive pressure will build up causing product to spurt out when the draw valve is opened.**

Drain the product from the freezing cylinder and the mix hopper.

### Step 2

When the flow of product stops, touch the WASH and PUMP symbols  , cancelling the WASH and PUMP modes. Close the draw valve.

### Step 3

Remove the agitator, cotter pin, mix feed tube, pump clip and the assembled air/mix pump.

**Repeat these steps for the other side of the machine.**

## Rinsing

### Step 1

Pour two gallons (7.6 liters) of cool, clean water into the mix hopper. With the white hopper brush, scrub the mix hopper, the mix level sensing probe, and the outside of the agitator drive shaft housing. Using the double ended brush, brush clean the mix inlet hole. (See Figure 78.)

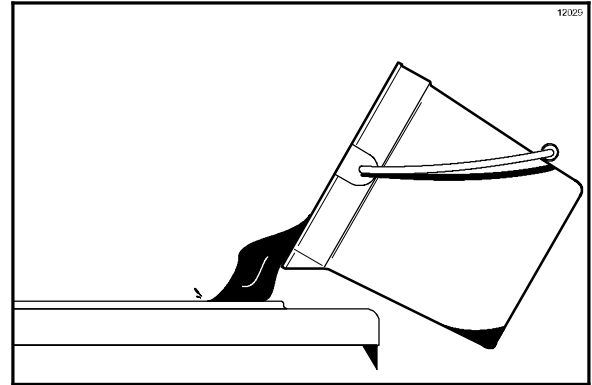



Figure 78

**Note:** Do not brush clean the mix inlet hole while the machine is in the WASH mode.

### Step 2

With a pail beneath the door spouts, raise the prime plug and touch the WASH symbol .

### Step 3

When a steady stream of rinse water is flowing from the prime plug opening in the bottom of the freezer door, open the draw valve. Drain all the rinse water from the door spout. Close the draw valve and push the prime plug down.

### Step 4

Touch the WASH symbol, , cancelling the Wash mode.

### Step 5

Repeat this procedure using clean, warm water, until the water being discharged is clear.

**Repeat these steps for the other side of the machine.**

## Hopper Cleaning

### Step 1

Prepare a pail of cleaning/sanitizing solution with an active chlorine concentrate of 100 - 200 PPM. USE WARM WATER AND FOLLOW THE MANUFACTURER'S SPECIFICATIONS.

### Step 2

With the prime plug pushed down, pour the cleaning solution into the hopper. Allow the solution to flow into the freezing cylinder.

### Step 3

Using the white hopper brush, clean the mix hopper, the mix level sensing probes, and the outside of the agitator drive shaft housing. Using the double ended brush, clean the mix inlet hole. (**Note:** Do not brush clean the mix inlet hole while the machine is in the Wash mode.)

### Step 4

Touch the WASH symbol . This will cause the cleaning solution in the freezing cylinder to come in contact with all areas of the freezing cylinder. Wait at least 5 minutes before proceeding with these instructions.

### Step 5

Place an empty pail beneath the door spouts.

### Step 6

Raise the prime plug.

### Step 7

When a steady stream of cleaning solution is flowing from the prime plug opening in the bottom of the freezer door, open the draw valve. Draw off all the solution.

### Step 8

Once the cleaning solution stops flowing from the door spout, close the draw valve and the prime plug.

### Step 9

Touch the WASH symbol , cancelling the Wash mode.

**Repeat these steps on the other side of the machine.**

## Disassembly



**MAKE SURE THE POWER SWITCH IS IN THE "OFF" POSITION!** Failure to follow this instruction may result in severe personal injury from hazardous moving parts.

### Step 1

Remove the handscrews, freezer door, beaters, scraper blades, and drive shafts with drive shaft seals from the freezing cylinders.

### Step 2

Remove the scraper blade clips from the scraper blades.

### Step 3

Remove the drive shaft seal from each drive shaft.

### Step 4

From each pump cylinder, remove the retaining pin, mix inlet adaptor, valve cap, pump gasket, and the piston. Remove the o-ring from the piston and valve cap.

### Step 5

Remove the freezer door gaskets, front bearings, pivot pin, draw handles, draw valves, prime plugs, and design caps. Remove the o-rings from the draw valves.

### Step 6

Remove the pump drive shafts from the drive hubs in the rear wall of the mix hoppers. (See Figure 79.)

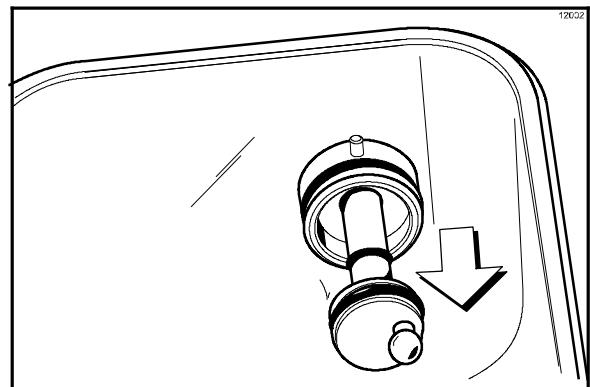

Figure 79



### Step 7

Remove the two small o-rings and one large o-ring from each pump drive shaft.

### Step 8

Remove the front drip tray and splash shield.

### Step 9

Remove all drip pans. Take all parts removed in steps 1 - 9 the sink for cleaning. (See Figure 80.)

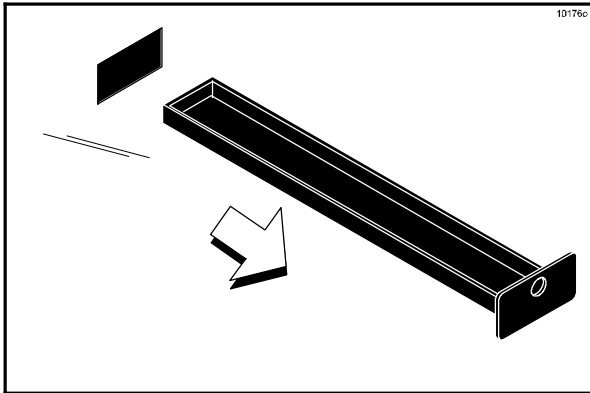

Figure 80

**Note:** If the drip pans are filled with an excessive amount of mix, it is an indication that the drive shaft seal(s) or o-ring(s) should be replaced or properly lubricated.

## Brush Cleaning

### Step 1

Prepare a sink with cleaning/sanitizing solution with an active chlorine concentrate of 100 - 200 PPM. USE WARM WATER AND FOLLOW THE MANUFACTURER'S SPECIFICATIONS. Make sure all brushes provided with the freezer are available for brush cleaning.

### Step 2

Thoroughly brush clean all disassembled parts in the cleaning solution, making sure all lubricant and mix film is removed. Be sure to brush all surfaces and holes, especially the holes in the pump components and the draw valve holes in the freezer door.

Rinse all parts with clean, warm water. Place the parts on a clean, dry surface to air dry overnight.

### Step 3

Return to the freezer with a small amount of cleaning solution. Using the black brush, clean the

rear shell bearing at the back of each freezing cylinder. (See Figure 81.)

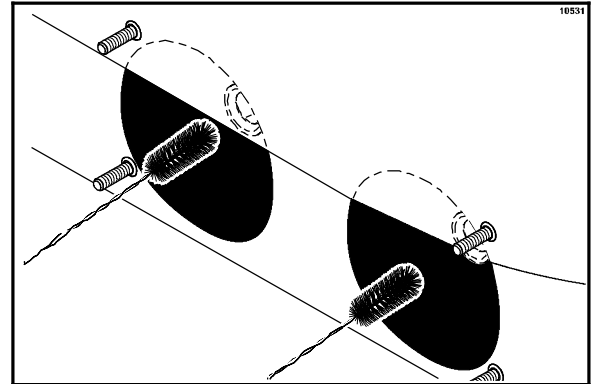

Figure 81

### Step 4

Using the black brush, clean the drive hub opening in the rear wall of each mix hopper. (See Figure 82.)

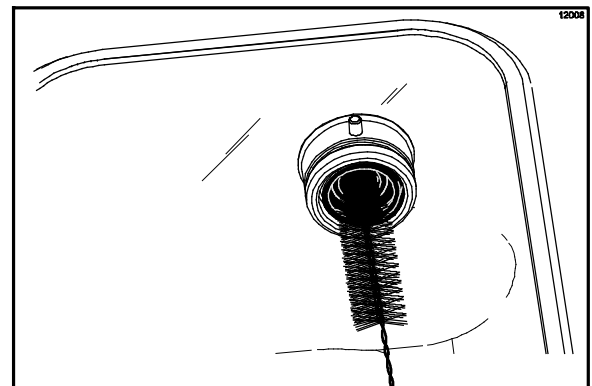

Figure 82

### Step 5

Wipe all exterior surfaces of the freezer with a clean, sanitized towel.

**Note:** The brush clean counter will reset to zero at this time.

# Section 7      Important: Operator Checklist

---

## During Cleaning and Sanitizing



Cleaning and sanitizing schedules are governed by federal, state, or local regulatory agencies, and must be followed accordingly. If the unit has a “Standby mode”, it must not be used in lieu of proper cleaning and sanitizing procedures and frequencies set forth by the ruling health authority. The following check points should be stressed during the cleaning and sanitizing operations.

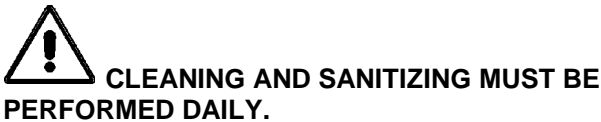

## Troubleshooting Bacterial Count

- 1. Thoroughly clean and sanitize the machine regularly, including complete disassembly and brush cleaning.
- 2. Use all brushes supplied for thorough cleaning. The brushes are specially designed to reach all mix passageways.
- 3. Use the white bristle brush to clean the mix inlet hole which extends from the mix hopper down to the rear of the freezing cylinder.
- 4. Use the black bristle brush to thoroughly clean the rear shell bearing located at the rear of the freezing cylinder and the drive hub opening in the rear wall of the mix hopper. Be sure there is a generous amount of cleaning solution on the brush.
- 5. Properly prepare the cleaning and sanitizing solutions. Read and follow the label directions carefully. Too strong of a solution may damage the parts and too weak of a solution will not do an adequate job of cleaning or sanitizing.
- 6. The temperature of mix in the mix hopper and walk-in cooler should be below 40°F (4.4°C).

- 7. Discard remaining mix from the freezer during “Cleaning Procedures”.

## Regular Maintenance Checks

- 1. Replace scraper blades that are nicked or damaged. Before installing the beater assembly, be certain that scraper blades are properly attached to the helix.
- 2. Check the rear shell bearing for signs of wear (excessive mix leakage in rear drip pan) and be certain it is properly cleaned.
- 3. Using a screwdriver and cloth towel, keep the rear shell bearing and the female hex drive socket clean and free of lubricant and mix deposits.
- 4. Dispose of o-rings and seals if they are worn, torn, or fit too loosely, and replace with new ones.
- 5. Follow all lubricating procedures as outlined in “Assembly”.
- 6. If your machine is air cooled, check the condensers for accumulation of dirt and lint. Dirty condensers will reduce the efficiency and capacity of the machine. Condensers should be cleaned **monthly** with a soft brush. **Never** use screwdrivers or other metal probes to clean between the fins. **Note:** For machines equipped with an air filter, it will be necessary to vacuum clean the filters on a monthly schedule.



**Caution: Always disconnect electrical power prior to cleaning the condenser.** Failure to follow this instruction may result in electrocution.

- 7. If your machine is water cooled, check the water lines for kinks or leaks. Kinks can occur when the machine is moved back and forth for cleaning or maintenance purposes. Deteriorated or cracked water lines should be replaced only by an authorized Taylor distributor.

## Winter Storage

If the place of business is to be closed during the winter months, it is important to protect the freezer by following certain precautions, particularly if the building is subject to freezing conditions.

Disconnect the freezer from the main power source to prevent possible electrical damage.

On water cooled freezers, disconnect the water supply. Relieve pressure on the spring in the water valve. Use air pressure on the outlet side to blow out any water remaining in the condenser. **This is extremely important.** Failure to follow this procedure may cause severe and costly damage to the refrigeration system.

Your local Taylor Distributor can perform this winter storage service for you.

Wrap detachable parts of the freezer such as beater, blades, drive shaft, and freezer door, and place them in a protected dry place. Rubber trim parts and gaskets can be protected by wrapping them with moisture-proof paper. All parts should be thoroughly cleaned of dried mix or lubrication which attract mice and other vermin.

It is recommended that an authorized service technician perform winter storage draining, to insure all water has been removed. This will guard against freezing and rupturing of the components.

# Section 8

# Troubleshooting Guide

| PROBLEM   | PROBABLE CAUSE  | REMEDY  | PAGE REF. |
|---|---|---|-----------|
| 1. No product is being dispensed.                   | a. Low on mix. The MIX OUT light is on.                                 | a. Add mix to mix hopper. Return to AUTO mode.  | 34        |
|   | b. Power switch is in the OFF position.                                 | b. Turn power switch ON and select AUTO.  | 33        |
|   | c. Machine not in AUTO mode.  | c. Select AUTO and allow machine to cycle off before drawing product.   | 34        |
|   | d. Beater motor is out on reset. The BEATER OVERLOAD message displayed. | d. Turn machine off. Press the reset button. Restart the machine in AUTO.   | ---       |
|   | e. Pump motor control is out on internal overload.                      | e. Turn power switch off. Remove and clean mix pump. Allow at least two minutes for power switch to remain off for control to reset. Once power is restored, before installing pump, press pump key and verify the pump shaft rotates counter-clockwise.<br><b>Note:</b> If this does not correct the problem or if rotation is clockwise, call an authorized service technician. | ---       |
|   | f. Feed tube or check ring not properly installed.                      | f. Make sure feed tube and rubber check ring are properly installed.  | 31, 34    |
|   | g. Butterfat buildup in the pump.                                       | g. Carefully remove the mix pump, clean and reinstall.  | 36        |
|   | h. Freeze-up in mix inlet hole.   | h. Call an authorized service technician.   | ---       |
|   | i. The mix pump ball crank is broken.                                   | i. Call an authorized service technician.   | ---       |
| 2. No control panel functions (power switch is ON). | a. Machine is unplugged.  | a. Plug into wall receptacle.   | ---       |
|   | b. Circuit breaker OFF or blown fuse.                                   | b. Turn the breaker ON or replace the fuse.   | ---       |

| PROBLEM  | PROBABLE CAUSE   | REMEDY  | PAGE REF. |
|--|--|---|-----------|
| 3. The product is too soft.                          | a. Draw rate is set too fast.  | a. Adjust draw rate: 5 to 7-1/2 oz. (142 g. to 213 g.) of product by weight in 10 seconds.  | 29        |
| 4. The product is too thick.                         | a. Freezing cylinder not primed correctly.                           | a. Drain the freezing cylinder and reprime the machine.   | 34        |
|  | b. Air/mix pump incorrectly assembled.                               | b. Assemble and lubricate according to instructions in this manual.   | 30        |
|  | c. The viscosity control is set too cold.                            | c. Call an authorized service technician.   | ---       |
|  | d. Freeze-up in mix inlet hole.                                      | d. Call an authorized service technician.   | ---       |
| 5. The mix in the hopper is too warm.                | a. Hopper cover is not in position.                                  | a. Clean and sanitize hopper cover and place in position.   | 34        |
|  | b. Agitator is not installed.  | b. Clean, sanitize, and install the agitator.   | 34        |
|  | c. The hopper temperature is out of adjustment.                      | c. Call an authorized service technician.   | ---       |
| 6. The mix in the hopper is too cold.                | a. The hopper temperature is out of adjustment.                      | a. Call an authorized service technician.   | ---       |
| 7. Mix Low and Mix Out probes are not functioning.   | a. Milkstone build-up in the hopper.                                 | a. Clean hoppers thoroughly.  | 37        |
| 8. The mix pump will not operate.                    | a. Pump motor control is out on internal overload.                   | a. Turn power switch off. Remove and clean mix pump. Allow at least two minutes for power switch to remain off, for control to reset. Once power is restored, before installing pump, press pump key and verify pump shaft rotates counter-clockwise.<br><b>Note:</b> If rotation is clockwise, call authorized service technician. | ---       |
| 9. Product is collecting on top of the freezer door. | a. The top o-ring on draw valve is improperly lubricated or is worn. | a. Lubricate properly or replace the o-ring.  | 28        |

| <b>PROBLEM</b>   | <b>PROBABLE CAUSE</b>   | <b>REMEDY</b>  | <b>PAGE REF.</b> |
|--|---|--|------------------|
| 10. Excessive mix leakage from the bottom of door spout. | a. Bottom o-ring on draw valve is improperly lubricated or is worn.                           | a. Lubricate properly or replace the o-ring.   | 28               |
| 11. Excessive mix leakage into the drip pan.             | a. The seal on drive shaft is improperly lubricated or is worn.                               | a. Lubricate properly or replace the seal.   | 25               |
|  | b. The seal is installed inside-out on the drive shaft.                                       | b. Install correctly.  | 25               |
|  | c. Inadequate lubrication of the drive shaft.   | c. Lubricate properly.   | 25               |
|  | d. The drive shaft and beater assembly work forward.  | d. Call an authorized service technician.  | ---              |
|  | e. Worn rear shell bearing.   | e. Call an authorized service technician.  | ---              |
|  | f. Gear box out of alignment.   | f. Call an authorized service technician.  | ---              |
| 12. The drive shaft is stuck in the drive coupling.      | a. Mix and lubricant collected in drive coupling.   | a. Brush clean the rear shell bearing area regularly.  | 37               |
|  | b. Rounded corners of drive shaft, drive coupling, or both.                                   | b. Call an authorized service technician.  | ---              |
|  | c. Gear box is out of alignment.  | c. Call an authorized service technician.  | ---              |
| 13. The freezing cylinder walls are scored.              | a. Missing or worn front bearing.   | a. Install or replace the front bearing.   | 27               |
|  | b. Scraper blades and/or clips are damaged.   | b. Replace scraper blades and/or clips.  | 26               |
|  | c. Unit was placed in AUTO before all sanitizing solution was removed from freezing cylinder. | c. Place unit in AUTO only after priming is complete and all sanitizing solution is removed. | 33               |
|  | d. Broken freezer door baffle rod.  | d. Replace freezer door.   | ---              |
|  | e. Broken beater pins.  | e. Replace beater assembly.  | 26               |
|  | f. Beater assembly is bent.   | f. Replace beater assembly.  | ---              |
|  | g. Gear box is out of alignment.  | g. Call an authorized service technician.  | ---              |

| <b>PROBLEM</b>                                    | <b>PROBABLE CAUSE</b>                      | <b>REMEDY</b>  | <b>PAGE REF.</b> |
|---|--|--|------------------|
| 14. The product makes a popping sound when drawn. | a. Draw rate is set too fast.              | a. Adjust draw rate: 5 to 7-1/2 oz. (142 g. to 213 g.) of product by weight in 10 seconds. | 29               |
|   | b. Pump assembled incorrectly.             | b. Assemble and lubricate according to instructions in this manual.                        | 30               |
|   | c. Freezing cylinder not primed correctly. | c. Drain the freezing cylinder and reprime the machine.                                    | 34               |

## Section 9

## Parts Replacement Schedule

| PART DESCRIPTION             | EVERY 3 MONTHS | EVERY 6 MONTHS                 | ANNUALLY |
|------------------------------|----------------|--------------------------------|----------|
| Scraper Blade                | X              |                                |          |
| Drive Shaft Seal             | X              |                                |          |
| Freezer Door Gasket          | X              |                                |          |
| Front Bearing                | X              |                                |          |
| Front Beater Shoes           | X              |                                |          |
| Design Caps                  | X              |                                |          |
| Draw Valve O-Ring            | X              |                                |          |
| Mix Feed Tube O-Ring         | X              |                                |          |
| Pump O-Ring                  | X              |                                |          |
| Prime Plug O-Ring            | X              |                                |          |
| Pump Valve Gasket            | X              |                                |          |
| Mix Feed Tube Check Ring     | X              |                                |          |
| Pump Drive Shaft O-Ring      | X              |                                |          |
| White Bristle Brush, 3" x 7" |                | Inspect & Replace if Necessary | Minimum  |
| White Bristle Brush, 1" x 2" |                | Inspect & Replace if Necessary | Minimum  |
| Black Bristle Brush, 1" x 2" |                | Inspect & Replace if Necessary | Minimum  |
| Double-Ended Brush           |                | Inspect & Replace if Necessary | Minimum  |



# Section 10 Limited Warranty on Equipment

## TAYLOR COMPANY LIMITED WARRANTY ON FREEZERS

Taylor Company, a division of Carrier Commercial Refrigeration, Inc. ("Taylor") is pleased to provide this limited warranty on new Taylor-branded freezer equipment available from Taylor to the market generally (the "Product") to the original purchaser only.

### LIMITED WARRANTY

Taylor warrants the Product against failure due to defect in materials or workmanship under normal use and service as follows. All warranty periods begin on the date of original Product installation. If a part fails due to defect during the applicable warranty period, Taylor, through an authorized Taylor distributor or service agency, will provide a new or re-manufactured part, at Taylor's option, to replace the failed defective part at no charge for the part. Except as otherwise stated herein, these are Taylor's exclusive obligations under this limited warranty for a Product failure. This limited warranty is subject to all provisions, conditions, limitations and exclusions listed below and on the reverse (if any) of this document.

| Product                | Part  | Limited Warranty Period |
|------------------------|---|-------------------------|
| <b>Soft Serve</b>      | Insulated shell assembly  | Five (5) years          |
| <b>Frozen Yogurt</b>   | Refrigeration compressor  | Five (5) years          |
| <b>Shakes</b>          | (except service valve)  |                         |
| <b>Smoothies</b>       | Beater motors   | Two (2) years           |
| <b>Frozen Beverage</b> | Beater drive gear   | Two (2) years           |
| <b>Batch Desserts</b>  | Printed circuit boards and Softech controls beginning with serial number H8024200 | Two (2) years           |
|                        | Parts not otherwise listed in this table or excluded below                        | One (1) year            |

### LIMITED WARRANTY CONDITIONS

1. If the date of original installation of the Product cannot be verified, then the limited warranty period begins ninety (90) days from the date of Product manufacture (as indicated by the Product serial number). Proof of purchase may be required at time of service.
2. This limited warranty is valid only if the Product is installed and all required service work on the Product is performed by an authorized Taylor distributor or service agency, and only if genuine, new Taylor parts are used.
3. Installation, use, care, and maintenance must be normal and in accordance with all instructions contained in the Taylor Operator's Manual.
4. Defective parts must be returned to the authorized Taylor distributor or service agency for credit.
5. The use of any refrigerant other than that specified on the Product's data label will void this limited warranty.

### LIMITED WARRANTY EXCEPTIONS

This limited warranty does **not** cover:

1. Labor or other costs incurred for diagnosing, repairing, removing, installing, shipping, servicing or handling of defective parts, replacement parts, or new Products.
2. Normal maintenance, cleaning and lubrication as outlined in the Taylor Operator's Manual, including cleaning of condensers.

3. Replacement of wear items designated as Class "000" parts in the Taylor Operator's Manual.
4. External hoses, electrical power supplies, and machine grounding.
5. Parts not supplied or designated by Taylor, or damages resulting from their use.
6. Return trips or waiting time required because a service technician is prevented from beginning warranty service work promptly upon arrival.
7. Failure, damage or repairs due to faulty installation, misapplication, abuse, no or improper servicing, unauthorized alteration or improper operation or use as indicated in the Taylor Operator's Manual, including but not limited to the failure to use proper assembly and cleaning techniques, tools, or approved cleaning supplies.
8. Failure, damage or repairs due to theft, vandalism, wind, rain, flood, high water, water, lightning, earthquake or any other natural disaster, fire, corrosive environments, insect or rodent infestation, or other casualty, accident or condition beyond the reasonable control of Taylor; operation above or below the electrical or water supply specification of the Product; or components repaired or altered in any way so as, in the judgment of the Manufacturer, to adversely affect performance, or normal wear or deterioration.
9. Any Product purchased over the Internet.
10. Failure to start due to voltage conditions, blown fuses, open circuit breakers, or damages due to the inadequacy or interruption of electrical service.
11. Electricity or fuel costs, or increases in electricity or fuel costs from any reason whatsoever.
12. Damages resulting from the use of any refrigerant other than that specified on the Product's data label will void this limited warranty.
13. Any cost to replace, refill or dispose of refrigerant, including the cost of refrigerant.
14. **ANY SPECIAL, INDIRECT OR CONSEQUENTIAL PROPERTY OR COMMERCIAL DAMAGE OF ANY NATURE WHATSOEVER.** Some jurisdictions do not allow the exclusion of incidental or consequential damages, so this limitation may not apply to you.

This limited warranty gives you specific legal rights, and you may also have other rights which vary from jurisdiction to jurisdiction.

#### **LIMITATION OF WARRANTY**

**THIS LIMITED WARRANTY IS EXCLUSIVE AND IS IN LIEU OF ALL OTHER WARRANTIES, CONDITIONS AND/OR REMEDIES UNDER THE LAW, INCLUDING ANY IMPLIED WARRANTIES OR CONDITIONS OF MERCHANTABILITY OR FITNESS FOR A PARTICULAR PURPOSE. THE ORIGINAL OWNER'S SOLE REMEDY WITH RESPECT TO ANY PRODUCTS SHALL BE REPAIR OR REPLACEMENT OF DEFECTIVE COMPONENTS UNDER THE TERMS OF THIS LIMITED WARRANTY. ALL RIGHTS TO CONSEQUENTIAL OR INCIDENTAL DAMAGES (INCLUDING CLAIMS FOR LOST SALES, LOST PROFITS, PRODUCT LOSS, PROPERTY DAMAGES OR SERVICE EXPENSES) ARE EXPRESSLY EXCLUDED. THE EXPRESS WARRANTIES MADE IN THIS LIMITED WARRANTY MAY NOT BE ALTERED, ENLARGED, OR CHANGED BY ANY DISTRIBUTOR, DEALER, OR OTHER PERSON, WHATSOEVER.**

#### **LEGAL REMEDIES**

The owner **must** notify Taylor in writing, by certified or registered letter to the following address, of any defect or complaint with the Product, stating the defect or complaint and a specific request for repair, replacement, or other correction of the Product under warranty, mailed at least thirty (30) days before pursuing any legal rights or remedies.

Taylor Company  
a division of Carrier Commercial Refrigeration, Inc.  
750 N. Blackhawk Blvd.  
Rockton, IL 61072, U.S.A.

# Section 11

# Limited Warranty on Parts

## TAYLOR COMPANY LIMITED WARRANTY ON TAYLOR GENUINE PARTS

Taylor Company, a division of Carrier Commercial Refrigeration, Inc. ("Taylor") is pleased to provide this limited warranty on new Taylor genuine replacement components and parts available from Taylor to the market generally (the "Parts") to the original purchaser only.

### LIMITED WARRANTY

Taylor warrants the Parts against failure due to defect in materials or workmanship under normal use and service as follows. All warranty periods begin on the date of original installation of the Part in the Taylor unit. If a Part fails due to defect during the applicable warranty period, Taylor, through an authorized Taylor distributor or service agency, will provide a new or re-manufactured Part, at Taylor's option, to replace the failed defective Part at no charge for the Part. Except as otherwise stated herein, these are Taylor's exclusive obligations under this limited warranty for a Part failure. This limited warranty is subject to all provisions, conditions, limitations and exclusions listed below and on the reverse (if any) of this document.

| Part's Warranty Class Code or Part            | Limited Warranty Period |
|---|-------------------------|
| Class 103 Parts <sup>1</sup>                  | Three (3) months        |
| Class 212 Parts <sup>2</sup>                  | Twelve (12) months      |
| Class 512 Parts                               | Twelve (12) months      |
| Class 000 Parts                               | No warranty             |
| Taylor Part #072454 (Motor-24VDC *C832/C842*) | Four (4) years          |

### LIMITED WARRANTY CONDITIONS

1. If the date of original installation of the Part cannot be otherwise verified, proof of purchase may be required at time of service.
2. This limited warranty is valid only if the Part is installed and all required service work in connection with the Part is performed by an authorized Taylor distributor or service agency.
3. The limited warranty applies only to Parts remaining in use by their original owner at their original installation location in the unit of original installation.
4. Installation, use, care, and maintenance must be normal and in accordance with all instructions contained in the Taylor Operator's Manual.
5. Defective Parts must be returned to the authorized Taylor distributor or service agency for credit.
6. This warranty is not intended to shorten the length of any warranty coverage provided pursuant to a separate Taylor Limited Warranty on freezer or grill equipment.
7. The use of any refrigerant other than that specified for the unit in which the Part is installed will void this limited warranty.

<sup>1, 2</sup> Except that Taylor Part #032129SER2 (Compressor-Air-230V SERV) and Taylor Part #075506SER1 (Compressor-Air-115V 60HZ) shall have a limited warranty period of twelve (12) months when used in Taylor freezer equipment and a limited warranty period of two (2) years when used in Taylor grill equipment.

## LIMITED WARRANTY EXCEPTIONS

This limited warranty does **not** cover:

1. Labor or other costs incurred for diagnosing, repairing, removing, installing, shipping, servicing or handling of defective Parts, replacement Parts, or new Parts.
2. Normal maintenance, cleaning and lubrication as outlined in the Taylor Operator's Manual, including cleaning of condensers or carbon and grease buildup.
3. Required service, whether cleaning or general repairs, to return the cooking surface assemblies, including the upper platen and lower plate, to an operational condition to achieve proper cooking or allow proper assembly of release sheets and clips as a result of grease build-up on the cooking surfaces, including but not limited to the platen and plate, sides of the shroud or top of the shroud.
4. Replacement of cooking surfaces, including the upper platen and lower plate, due to pitting or corrosion (or in the case of the upper platen, due to loss of plating) as a result of damage due to the impact of spatulas or other small wares used during the cooking process or as a result of the use of cleaners, cleaning materials or cleaning processes not approved for use by Taylor.
5. Replacement of wear items designated as Class "000" Parts in the Taylor Operator's Manual, as well as any release sheets and clips for the Product's upper platen assembly.
6. External hoses, electrical power supplies, and machine grounding.
7. Parts not supplied or designated by Taylor, or damages resulting from their use.
8. Return trips or waiting time required because a service technician is prevented from beginning warranty service work promptly upon arrival.
9. Failure, damage or repairs due to faulty installation, misapplication, abuse, no or improper servicing, unauthorized alteration or improper operation or use as indicated in the Taylor Operator's Manual, including but not limited to the failure to use proper assembly and cleaning techniques, tools, or approved cleaning supplies.
10. Failure, damage or repairs due to theft, vandalism, wind, rain, flood, high water, water, lightning, earthquake or any other natural disaster, fire, corrosive environments, insect or rodent infestation, or other casualty, accident or condition beyond the reasonable control of Taylor; operation above or below the gas, electrical or water supply specification of the unit in which a part is installed; or Parts or the units in which they are installed repaired or altered in any way so as, in the judgment of Taylor, to adversely affect performance, or normal wear or deterioration.
11. Any Part purchased over the Internet.
12. Failure to start due to voltage conditions, blown fuses, open circuit breakers, or damages due to the inadequacy or interruption of electrical service.
13. Electricity, gas or other fuel costs, or increases in electricity or fuel costs from any reason whatsoever.
14. Damages resulting from the use of any refrigerant other than that specified for the unit in which the Part is installed will void this limited warranty.
15. Any cost to replace, refill or dispose of refrigerant, including the cost of refrigerant.
16. **ANY SPECIAL, INDIRECT OR CONSEQUENTIAL PROPERTY OR COMMERCIAL DAMAGE OF ANY NATURE WHATSOEVER.** Some jurisdictions do not allow the exclusion of incidental or consequential damages, so this limitation may not apply to you.

This limited warranty gives you specific legal rights, and you may also have other rights which vary from jurisdiction to jurisdiction.

## LIMITATION OF WARRANTY

**THIS LIMITED WARRANTY IS EXCLUSIVE AND IS IN LIEU OF ALL OTHER WARRANTIES, CONDITIONS AND/OR REMEDIES UNDER THE LAW, INCLUDING ANY IMPLIED WARRANTIES OR CONDITIONS OF MERCHANTABILITY OR FITNESS FOR A PARTICULAR PURPOSE. THE ORIGINAL OWNER'S SOLE REMEDY WITH RESPECT TO ANY PRODUCTS SHALL BE REPAIR OR REPLACEMENT OF DEFECTIVE PARTS UNDER THE TERMS OF THIS LIMITED WARRANTY. ALL RIGHTS TO CONSEQUENTIAL OR INCIDENTAL DAMAGES (INCLUDING CLAIMS FOR LOST SALES, LOST PROFITS, PRODUCT LOSS, PROPERTY DAMAGES OR SERVICE EXPENSES) ARE EXPRESSLY EXCLUDED. THE EXPRESS WARRANTIES MADE IN THIS LIMITED WARRANTY MAY NOT BE ALTERED, ENLARGED, OR CHANGED BY ANY DISTRIBUTOR, DEALER, OR OTHER PERSON, WHATSOEVER.**

## LEGAL REMEDIES

The owner **must** notify Taylor in writing, by certified or registered letter to the following address, of any defect or complaint with the Part, stating the defect or complaint and a specific request for repair, replacement, or other correction of the Part under warranty, mailed at least thirty (30) days before pursuing any legal rights or remedies.

Taylor Company  
a division of Carrier Commercial Refrigeration, Inc.  
750 N. Blackhawk Blvd.  
Rockton, IL 61072, U.S.A.