

Frozen Beverage Freezer - Two Flavour, Gravity



ITEM No. _____

Model options:

- 432/1A Frozen Beverage Freezer (single phase)
- 432/3A Frozen Beverage Freezer (three phase)

Standard equipment:

- 1x Starter kit sanitiser sachets
- 1x White cleaning bucket
- 1x Tube Taylor food safe lubricant
- 1x Taylor cleaning brushes
- 1x Replacement tune up kit
- 12 Months parts & labour warranty

Optional extras:

- C206 cart with castors
- Panel spinner
- Top air discharge chute (factory order)
- Extended service contract (call for details)

Features:

Vary your menu by offering American style thick shakes, fruit smoothies, frozen cocktails & 'mocktails', iced coffee's & frappaccinos, slush and dairy-free vegan beverages. Serve two different flavours or products at the perfect level of thickness.

- ◆ **Freezing Cylinder** - Two, 3.8 litre
- ◆ **Hourly Production**** - Thick Shake - 40.8 litres (combined)
Fruit Slush - 34.1 litres
Frozen Cocktail - 23.8 litres (approximately)
- ◆ **Mix Hopper** - Two, 11.4 litre. Refrigerated to maintain mix below 5°C. Approved for dairy and non-dairy products.
- ◆ **Indicator Lights** - Add Mix light alerts the operator to add mix. When the Mix Out light flashes, the unit automatically shuts down to prevent damage.
- ◆ **Automatic Consistency Control** - A specially designed viscosity control automatically maintains superior product quality. An adjustable control allows the operator to serve a wide variety of frozen beverages at the desired thickness.
- ◆ **Illuminated Display** - Self-merchandising illuminated display back-lights the static cling flavour card and down-lights the dispensing door. Five static clings are provided: Frozen Cappuccino, Frozen Cocktails, Frozen Drinks, Shakes, and Smoothies.
- ◆ **Flavor Burst™ FB80S Compatible** (call for details)



Taylor UK (a division of HTG Trading Ltd)
106 Claydon Business Park, Gt. Blakenham,
Ipswich, Suffolk, IP6 0NL, United Kingdom
0800 838 896 - sales@taylor-company.co.uk
www.taylor-company.co.uk

432

Frozen Beverage Freezer - Two Flavour, Gravity

ITEM No. _____

Section view: (Dimensions shown in brackets in mm)

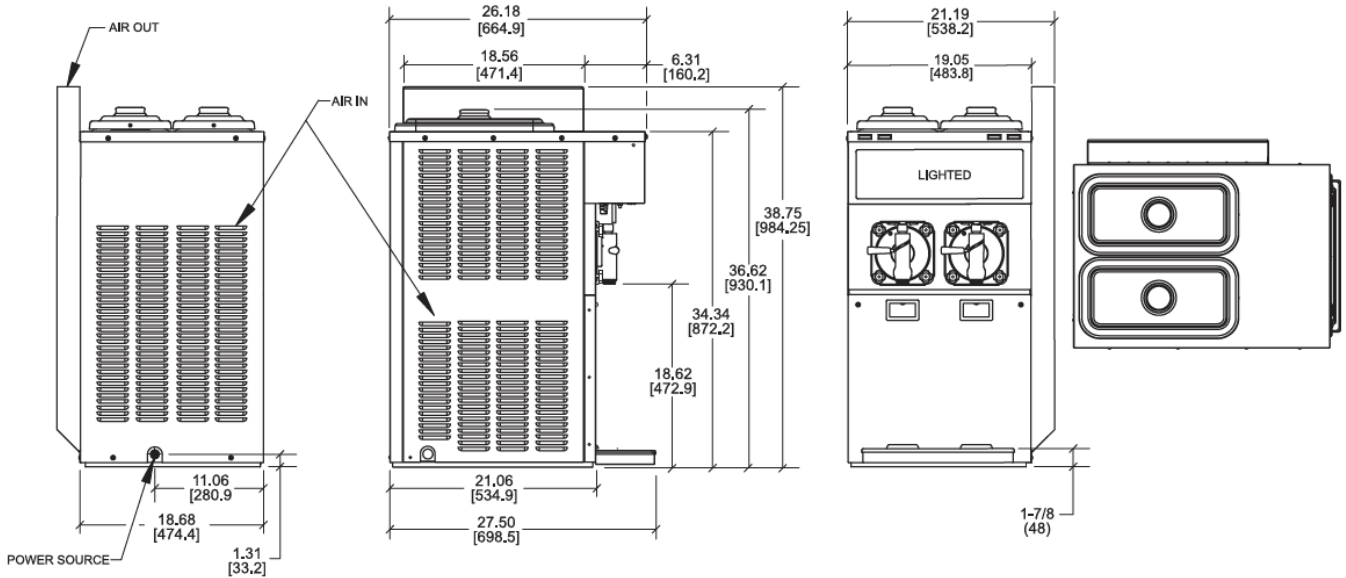

NOTE: FIGURES IN PARENTHESES INDICATE MILLIMETERS. / ALL DIMENSIONS PLUS OR MINUS 1/16 inch [1.5mm].

Shown with optional top air discharge chute.



Shown with optional top air discharge chute.

TAYLOR 432	SINGLE PHASE	THREE PHASE
External dimensions (WxDxH) inc. Handle	484 x 665 x 931 mm	
Net weight / crated weight (freezer only)	138.3 Kg / 162.4 Kg	
Wall clearance* (sides/back)	150mm / 0 mm	
Frozen beverage freezers are NOT designed for built-in installation		
Refrigeration system	7,500 BTU/hr - R449A	
Beater motor (No./Power)	2 - 0.25 HP	
Noise Level	≤ 78 dB (A)	
Cooling	Air ONLY	
Approximate hourly production**	Thick Shake - 40.8 ltr Fruit Slush - 34.1 ltr Frozen Cocktail - 23.8 ltr	
Voltage	230v / 50Hz / 1Ph	400v / 50Hz / 3Ph
Minimum circuit ampacity (left/right circuit)	13 amps	9 amps per phase
Circuit breaker / Type	16 amp / C-Type	10amp / C-Type
Isolator socket	16 amp (1P+N+E) 	16 amp (3P+N+E)

*Minimum air clearances **MUST** be met to assure adequate airflow for optimum performance of air cooled machines. Failure to allow adequate airflow will invalidate any warranty claim.
 **Hourly production figures are approximate and based on optimum operating conditions. Product type, ambient air temperature and air flow will effect the production capacity.
 •A dedicated power supply which can be completely disconnected is required for safe operation. Taylor equipment is not designed to be 'hard wired' and should never be operated on any form of extension lead. **Please consult a qualified electrician for correct installation advice.**

Data for air cooled units.



Taylor UK (a division of HTG Trading Ltd)
 106 Claydon Business Park, Gt. Blakenham,
 Ipswich, Suffolk, IP6 0NL, United Kingdom
 0800 838 896 - sales@taylor-company.co.uk
 www.taylor-company.co.uk

Due to continual research and development, these specifications are subject to change without notification - May 2024