

430

Frozen Beverage Freezer - Single Flavour, Gravity



Taylor 430 with optional spinner



Taylor 430 with optional branding

ITEM No. _____

Model options:

- 430/1A Frozen Beverage Freezer
 - 430/1A+SPINNER Beverage Freezer with spinner
- (AIR cooled as standard, water cooled units are available on request)

Standard equipment:

- 1x Starter kit sanitiser sachets
- 1x White cleaning bucket
- 1x Tube Taylor food safe lubricant
- 1x Taylor cleaning brushes
- 1x Replacement tune up kit
- 12 Months parts & labour warranty

Optional extras:

- Panel decals or branding
- Top air discharge chute (factory order)
- Extended service contract (call for details)

Features:

Vary your menu by offering American style thick shakes, fruit smoothies, frozen cocktails & 'mocktails', iced coffee's & frappaccinos, slush and dairy-free vegan beverages. All served at the perfect level of thickness.

- **Freezing Cylinder** - One, 3.8 litre
- **Hourly Production**** - Thick Shake - 40.8 litres
Fruit Slush - 34.1 litres
Frozen Cocktail - 23.8 litres (approximately)
- **Mix Hopper** - One, 13.2 litre. Refrigerated to maintain mix below 5°C. Approved for dairy and non-dairy products.
- **Indicator Lights** - Add Mix light alerts the operator to add mix. When the Mix Out light flashes, the unit automatically shuts down to prevent damage.
- **Automatic Consistency Control** - A specially designed viscosity control automatically maintains superior product quality. An adjustable control allows the operator to serve a wide variety of frozen beverages at the desired thickness.
- **Flavor Burst™ FB80S Compatible** (call for details)



Taylor UK (a division of HTG Trading Ltd)
106 Claydon Business Park, Gt. Blakenham,
Ipswich, Suffolk, IP6 0NL, United Kingdom
0800 838 896 - sales@taylor-company.co.uk
www.taylor-company.co.uk

Due to continual research and development, these specifications are subject to change without notification - Aug 2022

430

Frozen Beverage Freezer - Single Flavour, Gravity

ITEM No. _____

Section view: (Dimensions shown in brackets in mm)

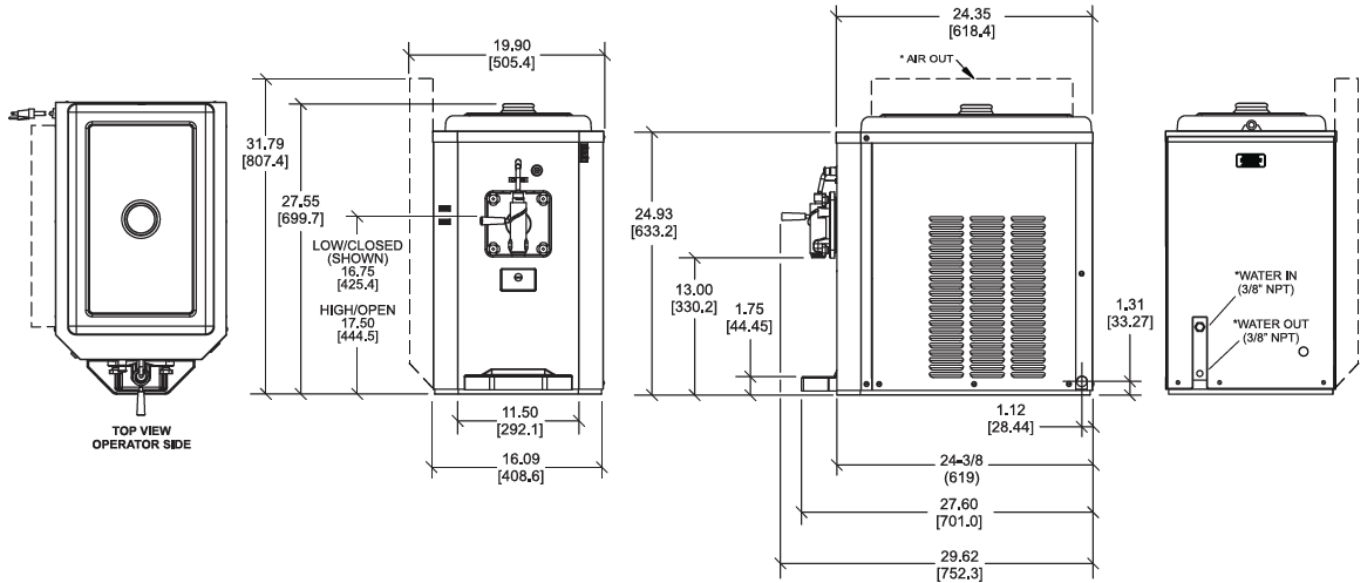

FIGURES IN BRACKETS INDICATE MILLIMETERS / DECIMAL DIMENSIONS EQUAL TO (PLUS OR MINUS 1/16 INCH [1.5mm]), * WATER COOLED ONLY

Shown with optional top air discharge chute.

TAYLOR 430	SINGLE PHASE
External dimensions (WxDxH) inc. Handle	409 x 753 x 700 mm
Net weight / crated weight (freezer only)	79.8 Kg / 93.9 Kg
Wall clearance* (sides/back)	150 mm / 0 mm
Frozen beverage freezers are NOT designed for built-in installation	
Refrigeration system	4.000 BTU/hr - R449A
Beater motor (No./Power)	1 - 0.25 HP
Noise Level	≤ 78 dB (A)
Cooling	Air (water cooled available on request)
Approximate hourly production**	Thick Shake - 40.8 ltr Fruit Slush - 34.1 ltr Frozen Cocktail - 23.8 ltr
Voltage	230v / 50Hz / 1Ph
Total amp draw	7.6 amps
Circuit breaker/fuse	13 amp
Isolator socket	13 amp (1P+N+E)

*Minimum air clearances **MUST** be met to assure adequate airflow for optimum performance of air cooled machines. Place the back of the unit against a wall to prevent recirculation of warm air. Failure to allow adequate airflow will invalidate any warranty claim.

**Hourly production figures are approximate and based on optimum operating conditions. Product type, ambient air temperature and air flow will effect the production capacity.

•A dedicated power supply which can be completely disconnected is required for safe operation. Taylor equipment is not designed to be 'hard wired' and should never be operated on any form of extension lead.
Please consult a qualified electrician for correct installation advice.

Data for air cooled units.



Taylor UK (a division of HTG Trading Ltd)
106 Claydon Business Park, Gt. Blakenham,
Ipswich, Suffolk, IP6 0NL, United Kingdom
0800 838 896 - sales@taylor-company.co.uk
www.taylor-company.co.uk

Due to continual research and development, these specifications are subject to change without notification - May 2024